

Liberty Pumps™

Installation Manual

5824000C

SumpJet™ - Water Powered Backup System

MODEL SJ10



Liberty Pumps

7000 Apple Tree Avenue, Bergen, NY 14416
Phone: (800) 543-2550
liberty@libertypumps.com
website: www.libertypumps.com

IMPORTANT:

Prior to installation, record Model, Serial Number, and Code Number from pump nameplate for future reference.

MODEL _____

SERIAL _____

TABLE OF CONTENTS

SECTION	1	GENERAL INFORMATION-----	3
SECTION	2	INTRODUCTION-----	4
SECTION	3	MECHANICAL INSTALLATION -----	5-7
SECTION	4	WARRANTY STATEMENT-----	7
SECTION	5	TEMPLATE -----	9

1 General Information

Before installation, read the following instructions carefully. Each Liberty Pump is individually factory tested to ensure proper performance. Closely following these instructions will eliminate potential operating problems, assuring years of trouble-free service.

This product must be installed in accordance to local plumbing codes which may require alternate procedures and additional redundant back flow protection devices, please contact the local authority having jurisdiction for information.

⚠WARNING

- **Risk of electric shock.** When installing the *SumpJet™*, Always disconnect any electric pumps from the power source before handling or making adjustments.
- **The *SumpJet™* is designed for use with municipal water supply**, and is intended to be used as an emergency backup to your existing pump system.
- The *SumpJet™* comes with a foot valve installed and therefore does not require a check valve on the discharge. The foot valve has a removable poppet. **Where freezing discharge pipes are a problem**, simply unscrew the strainer screen, remove the poppet and spring, and replace the strainer. The *SumpJet™* will now allow water to flow back into the pit, eliminating discharge pipe freezing.
- **Maximum water pressure** = 100 psi with the valve closed.
- **Minimum water pressure** = 30 psi with the valve open. (less pressure may not eject water from your basement)
- This unit must have a shut-off valve installed on the water supply line. (Refer to figure 3)
- For nominal backflow protection *SumpJet™* is pre-equipped with an internal check valve certified to ASME A112.18.3-2002 and ASME A112.18.1/CSA B125.1.2005.
- **Additional backflow protection must be provided by the installer to meet the requirements of the local plumbing code or the requirements of the local water authority.** Generally the minimum requirement for ordinary residential usage is a non-testable double check valve as certified per **ASSE 1024**, and the discharge of the water-powered sump pump should not be connected to the primary sump pump. Also, the discharge of the water-powered sump pump is not to be directly connected to the municipal drain. An air gap with a minimum 1" gap should be used, or the discharge should be directed onto the yard.
- The minimum requirement for **IAPMO** or **UPC** installations is the use of an **RPZ** backflow prevention device.
- The inlet of the *SumpJet™* is pre-equipped with a push-type pipe connector, SharkBite®, and can be used with PEX, CPVC, or copper pipe.
- Do not use pipe dope on inlet threads, and do not sweat copper fittings within 18" of *SumpJet™* body. Use PTFE (Teflon®) sealing tape only when assembling threaded fittings into *SumpJet™* inlet. Do not over tighten threaded inlet fitting, and do not hold onto float plunger shroud when tightening.
- Purge water line prior to connection to *SumpJet™* to insure debris does not enter unit and clog the operating valve.
- The *SumpJet™* utilizes a quick acting valve which, per UPC, requires the use of an approved water pressure absorbing device to prevent water hammer.
- **DO NOT use *SumpJet™* in hot water.**
- **The *SumpJet™* is designed for use in clear water only.** It is not designed to remove waste water, sewage, effluent, or water with debris in it.

WATER PRESSURE AT INLET OF <i>SumpJet™</i> WITH VALVE OPEN AND WATER FLOWING		SUMP WATER REMOVAL AT VARIOUS HEADS. (STATIC HEAD IN 1-1/2 PIPE OR LARGER)											
LIFT		4FT		1.21 M	8FT		2.4 M	12 FT		3.6 M	15 FT		4.5 M
PSI	KPA	GPM	GPH	M ³ /HR	GPM	GPH	M ³ /HR	GPM	GPH	M ³ /HR	GPM	GPH	M ³ /HR
20	138	11.0	660	2.5	5.8	348	1.3						
30	207	12.8	765	2.9	9	540	2.0	5.5	330	1.2			
40	276	15.4	924	3.5	12.5	750	2.8	9.3	558	2.1	7.2	432	1.6
50	345	17.2	1032	3.9	14.5	870	3.3	12	720	2.7	10	600	2.3
60	414	19.8	1185	4.5	17	1020	3.9	15.2	912	3.5	13.5	810	3.1

Note: For optimal performance minimum recommended operating pressure is 30 psi. Use of an RPZ may lower operating pressure.

2

Introduction

2-1 INTRODUCTION

This manual was prepared to assist you in the correct installation, operation, and maintenance of your Liberty Pumps **SumpJet™**. Please read it completely before installing the pump. Make certain that you are familiar with the contents, and the chapters on installation and operation are fully understood before running the pump.

Liberty products are designed for minimal maintenance. However, regular checks will ensure longer life and greater operating reliability.

WARRANTY: No repair work should be carried out during the warranty period without prior factory approval. To do so may render the warranty void.

SERIAL #: In all correspondence and reports, make certain that the pump serial number is given.

2-2 DESIGN OF PUMP

CAUTION

The Liberty **SumpJet™** is designed for emergency backup to your existing pump system. It uses the municipal water supply to evacuate water from the sump. It is not intended to be used as the main sump water removal pump. It is intended to remove clear sump water only. **Liberty Pumps recommends the use of an audible high water alarm with battery backup. (Liberty Model # ALM 2).** Prolonged use of the **SumpJet™** will result in increased municipal water consumption. The **SumpJet™** will use approximately 1 gallon of water to remove 2 gallons of sump water, depending on elevation.

2-3 INSPECTION UPON RECEIPT

The shipping container should be immediately inspected for damage that may have occurred in shipment. Exercise care in opening the shipping container to avoid damage to the pump. Remove any blocking and cushioning from within the container.

Check all cushioning for spare parts before discarding. Visually check the pump and any spare parts for damage. Report any damage or shortage of parts.

2-4 STORAGE BEFORE USE

Liberty pumps are shipped from the factory ready for installation and use. They should be held in storage if the pump station is not complete. If storage is necessary, the pump should remain in its shipping container. It should be stored in a warehouse or storage shed that has a clean, dry temperature-stable area where the pump and its container should be covered to protect it from water, dirt, dust, etc.

CAUTION

AT NO TIME SHOULD THE PUMP BE STORED WITHIN AN INCOMPLETE WET PIT. THE PUMP SHOULD NOT BE PLACED INTO THE PIT UNTIL IT CAN BE FULLY OPERATED.

2-5 LONG TERM STORAGE

If it is necessary to store a pump for a long period of time, it should be stored indoors in a clean, dry temperature-stable environment. The pump should be covered to protect it from dust, dirt and water.

Do not allow the pump to freeze.

2-6 MAINTENANCE

Installed pumps which are idle for long periods of time **should be manually operated once a month to ensure proper operation.** Check for proper operation of the float and clean any debris that may be on the float or the suction screen. Make sure that the float operates freely without any restrictions.

3

Mechanical Installation

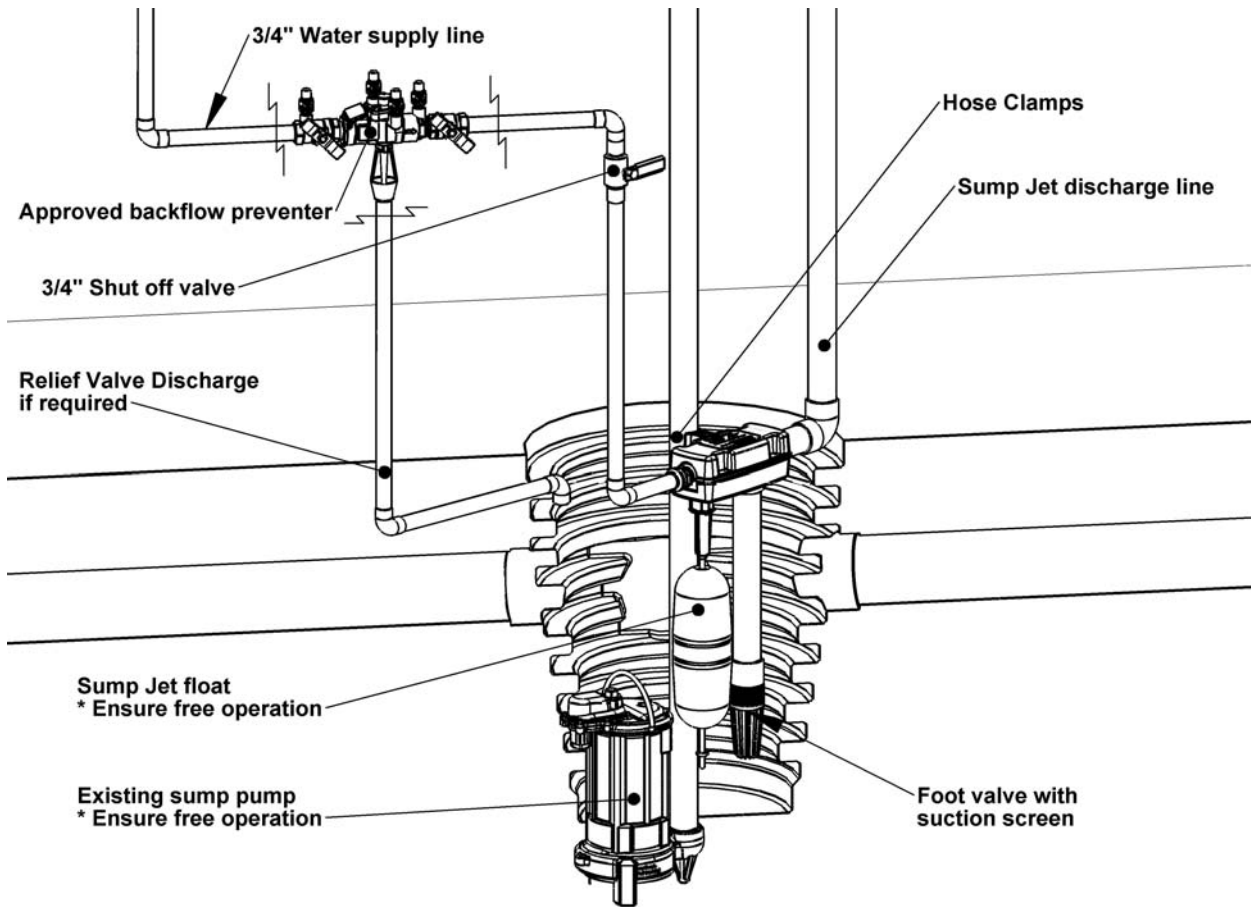

Figure 1 Typical installation

Note- The **SumpJet™** comes fully assembled. Only placement and connection is required.

3-1 For nominal backflow protection the **SumpJet™** is pre-equipped with an internal check valve certified to ASME A112.18.3-2002 and ASME A112.18.1/CSA B125.1.2005. Additional backflow protection must be provided by the installer to meet the requirements of the local plumbing code or the requirements of the local water authority. Generally the minimum requirement for ordinary residential usage is a non-testable double check valve as certified per ASSE 1024, and the discharge of the water-powered sump pump should not be connected to the primary sump pump. Also, the discharge of the water-powered sump pump is not to be directly connected to the municipal drain. An air gap with a minimum 1" gap should be used, or the discharge should be directed onto the yard. The minimum installation requirement for IAPMO or UPC requirements is the use of an RPZ backflow prevention device. Consult with your local authorities for your specific requirements.

3-2 **⚠WARNING**
Disconnect the existing sump pump from the electrical supply before installation of the **SumpJet™**.

3-3 **⚠WARNING** DO NOT USE A GARDEN HOSE. Garden hose is not designed to hold municipal pressure indefinitely. It could leak or burst and cause flooding. The **SumpJet™** requires permanent piping methods such as copper, PEX, or CPVC, or any other permanent plumbing method, be used for installation. To achieve maximum performance from the **SumpJet™** it is recommended that the unit is plumbed with 3/4" pipe.

3-4 The inlet of the **SumpJet™** is factory equipped with a SharkBite® push-type fitting. This fitting can be used with various approved 3/4-inch potable water tubing and pipe, such as PEX tubing (ASTM F876, CSA B137.5), copper pipe (ASTM B 88), or CPVC pipe (ASTM D 2846, CSA B137.6). Follow the instructions below for connecting the municipal water line to the SharkBite®. For more details on using the SharkBite® go to www.cashacme.com.

3-5 Using the Hose clamps provided, mount the **SumpJet™** to the existing discharge pipe. Place the unit so that the float level will operate a few inches above the turn on level of the existing sump pump. (Refer to figure 4). Tighten hose clamps on discharge pipe. NOTE: If this type of installation will not work refer to alternate installation 3-17.

3-6 After mounting the **SumpJet™**, you are ready to hook into the existing municipal water supply line. Shut off the municipal water supply, and plumb the tubing or piping into the municipal water supply line. Use the appropriate backflow prevention for your jurisdiction.

3-7 Prior to connecting water line to the **SumpJet™** purge the water line to insure it is free from debris, solder, pie sealant, etc.

3-8 To connect the water line to the SharkBite® cut the pipe or tubing end square. Ensure that there are no burrs or scratches 1" from the cut end. Mark the pipe or tubing 1" from the cut end to indicate proper insertion depth. If using PEX tubing the tube liner in the end of the SharkBite® must be used. For copper and CPVC piping the tube liner must be removed by using your fingers or pliers. Insert the tubing or pipe into the SharkBite® through the release collar to rest against the grab ring. Then push the tube or pipe firmly until it reaches the tube stop. To insure the tube or pipe is correctly inserted, check that the depth mark is up to the end of the release collar.

3-9 If the Shark fitting is removed for connection to other types of 3/4" NPT threaded fittings, make sure all sealing tape is removed from the threaded inlet of the **SumpJet™**. Use a small pick-type tool if necessary. Do not allow any debris to enter the valve body.

3-10 **CAUTION** If reconnecting the SharkBite® or other threaded fitting use **PTFE (Teflon®)** sealing tape only when assembling threaded fittings into **SumpJet™** inlet.

3-11 **CAUTION** Do not over tighten threaded inlet fitting, and do not hold onto float plunger shroud when tightening.

3-12 **CAUTION** **DO NOT SWEAT PIPES OR FITTINGS DIRECTLY CONNECTED TO THE **SumpJet™**. HEAT TRANSFERRED FROM THE COPPER WILL DAMAGE PLASTIC PARTS!**

3-13 Determine the length of discharge pipe required to the discharge exit point. Using schedule 40 PVC pipe, glue the discharge pipe into the socket elbow of the **SumpJet™**. Complete all discharge piping. Discharge piping should be routed to the yard outside the building.

NOTE: The **SumpJet™** comes complete with a foot valve. There is no need to install a check valve on the discharge pipe.

NOTE: If the discharge is emptying to a municipal drain then this unit must be used in conjunction with an "air gap". The "air gap" must be at least 1".

NOTE: The foot valve has a removable poppet. **Where freezing discharge pipes are a problem**, simply unscrew the strainer screen, remove the poppet and spring, and replace the strainer. The **SumpJet™** will now allow water to flow back into the pit, eliminating discharge pipe freezing.

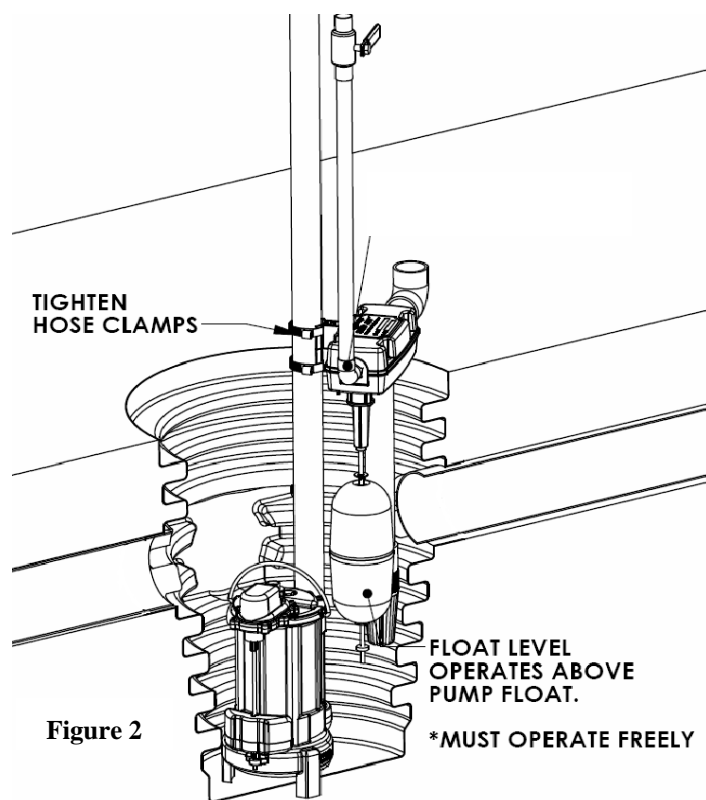

Figure 2

- 3-14 Turn the municipal water supply back on and open the shutoff valve. Check for leaks. Test the **SumpJet™** to ensure that it is operational. You will need to fill the sump pit with water by garden hose or bucket.
- 3-15 Re-connect primary electric sump pump to power supply.
- 3-16 If you want to replace the sump cover it will be necessary to add additional holes and slots to make access for the **SumpJet™** suction pipe and float rod. Refer to template provided in Figure (7) at the end of the manual.
- 3-17 If you cannot mount the **SumpJet™** to the pump discharge pipe you may use a piece of wood to mount the **SumpJet™**. Cut holes as per figure (7) at the end of the manual. There are 4 screw holes that you can use to fasten the **SumpJet™** to the wood. Use #8x2.5" long wood screws. Refer to Figure (6)

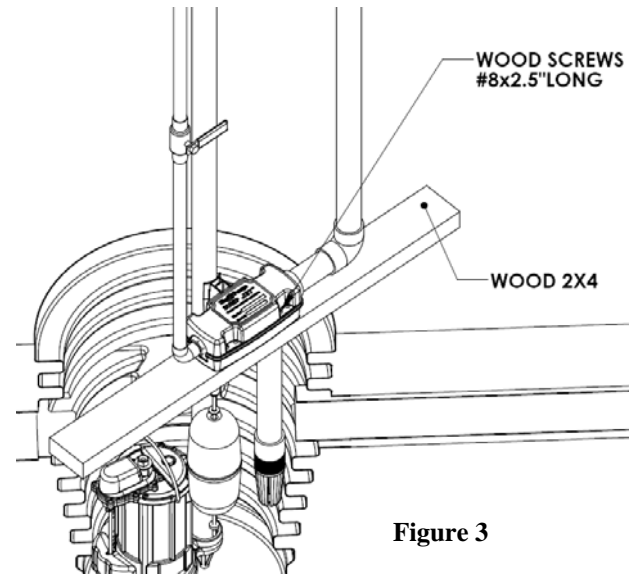

Figure 3

4 Warranty

Year Limited Warranty Liberty Pumps, Inc. warrants that pumps of its manufacture are free from all factory defects in material and workmanship for a period of 2 years from the date of purchase. The date of purchase shall be determined by a dated sales receipt noting the model and serial number of the pump. The dated sales receipt must accompany the returned pump if the date of return is more than 2 years from the "CODE" (date of manufacture) number noted on the pump nameplate. The manufacturer's obligation under this Warranty shall be limited to the repair or replacement of any parts found by the manufacturer to be defective, provided the part or assembly is returned freight prepaid to the manufacturer or its authorized service center, and provided that none of the following warranty-voiding characteristics are evident: The manufacturer shall not be liable under this Warranty if the product has not been properly installed; if it has been disassembled, modified, abused or tampered with; if the electrical cord has been damaged or improperly spliced; if the pump discharge has been reduced in size; if the pump has been used in hot water or water containing sand, lime, cement, gravel or other abrasives; if the product has been used to pump chemicals or hydrocarbons; if a non-submersible motor has been subjected to excessive moisture; or if the label bearing the serial and code number has been removed. Liberty Pumps, Inc. shall not be liable for any loss, damage or expenses resulting from installation or use of its products, or for consequential damages, including costs of removal, reinstallation or transportation. **There is no other express warranty. All implied warranties, including those of merchantability and fitness for a particular purpose, are limited to two years from the date of purchase.** This Warranty contains the exclusive remedy of the purchaser, and, where permitted, liability for consequential or incidental damages under any and all warranties are excluded.

5

Hole Template

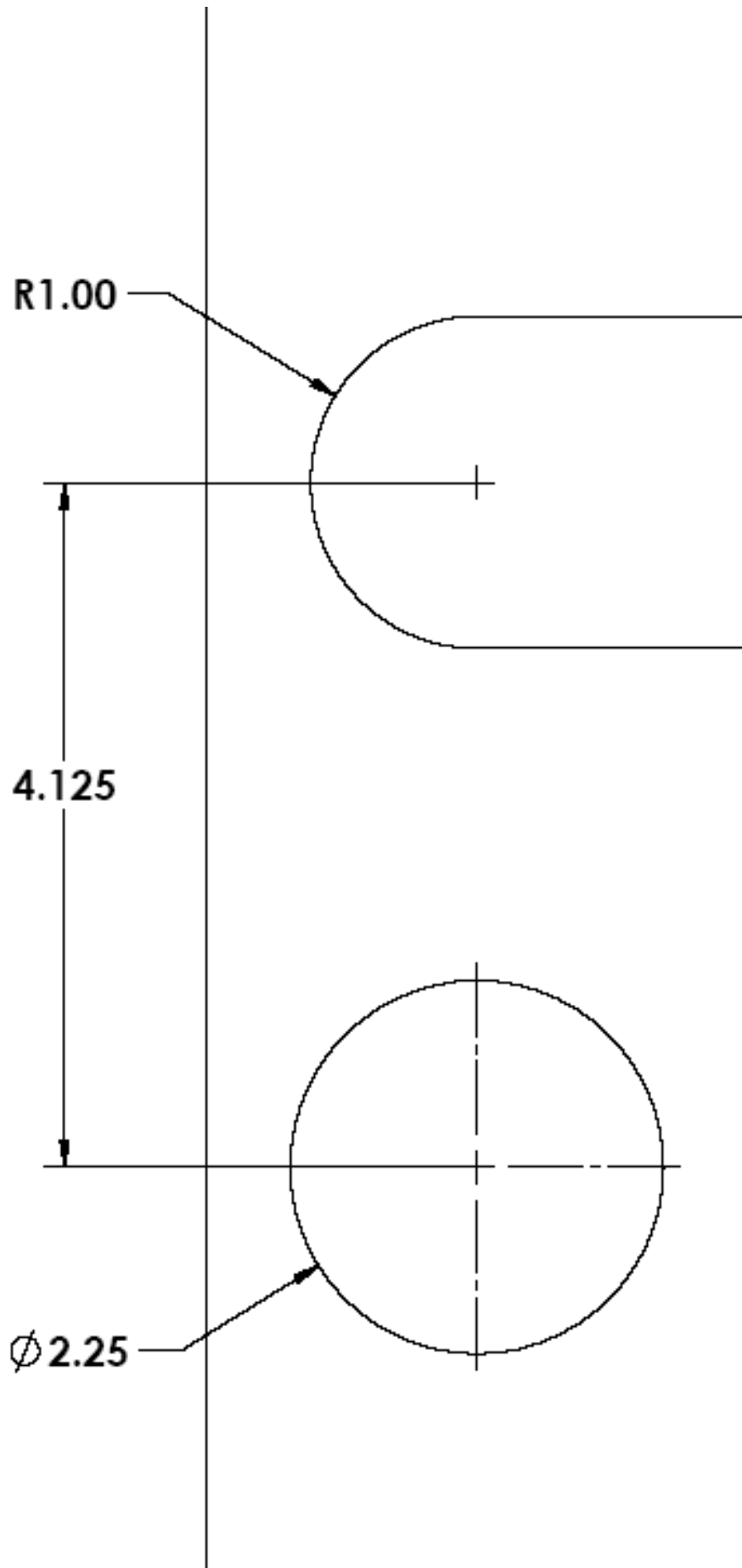

Figure 7