

Little GIANT[®]

Pump Company

PE-1 SERIES



Features

- Epoxy encapsulated motor
- 7' maximum lift
- 36 watts
- 1/4" MNPT discharge
- Impedance protected
- For submersible use only

Construction

- Motor — 1/125 HP Epoxy Encapsulated
- Maximum Flow Rate — 170 GPH @ 1'
- Maximum Head — 7'
- Intermittent Liquid Temp up to — 120° F
- Intake — Screened
- Discharge — 1/4" MNPT
- Housing — Glass-filled polyester
- Cover — Glass-filled polyester
- Volute — Polypropylene
- Impeller — Polypropylene
- Shaft Seal — Nitrile
- Screen — Polypropylene
- Electrical — 115V, 60HZ

Small submersible epoxy encapsulated pump for commercial, industrial and home use. Applications include statuary fountains, water displays, air conditioners, machine tool coolants, and many other applications where liquid must be transferred or recirculated. This compact 170 GPH pump features a 1/4" MNPT discharge, 7' shut-off head capability, screened inlet and a 6' power cord.

Little Giant Pump Co.

PE-1 SERIES

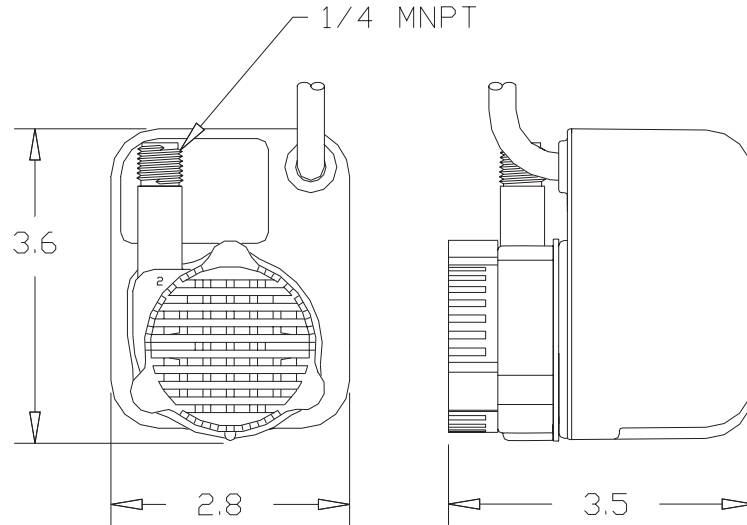

Specifications

Model No.	Item No.	Discharge Size	Listing(s)	HP	Volts	Hertz	Amps	Watts	Performance (GPH @ Head)			Shut Off		Pwr. Cord (ft)	Weight (Lbs.)
									1'	3'	5'	Feet	PSI		
PE-1	518200	1/4" MNPT	UL/CSA	1/125	115	60	0.6	36	170	140	100	7	3.0	6	3.00
PE-1H	518203	1/4" MNPT	UL/CSA	1/125	115	60	0.6	36	170	140	100	7	3.0	6	3.17

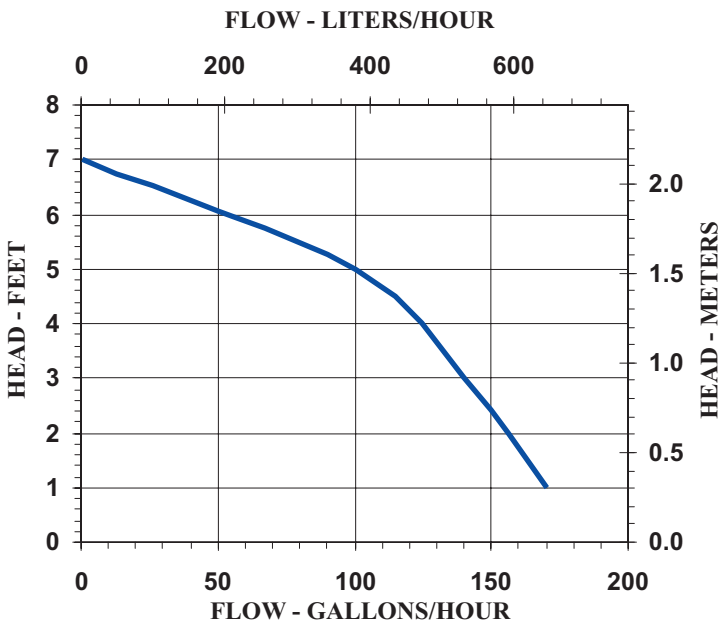

Replacement Parts

Volute	101375
Impeller	118441
Screen	118901
Gasket	101604

Little Giant Pump Co.
 PO Box 12010
 Okla. City, OK 73157
 Phone: 405.947.2511
 Fax: 405.228.1550
www.LittleGiantPump.com