

Little GIANT[®]

Pump Company

PE-2H SERIES



Features

- Epoxy encapsulated motor
- 12.2' maximum lift
- 47 watts
- 1/4" MNPT discharge
- Thermal overload protection
- For submersible use only

Construction

- Motor — 1/40 HP Epoxy Encapsulated
- Maximum Flow Rate — 300 GPH @ 1'
- Maximum Head — 12.2'
- Intermittent Liquid Temp. up to — 120° F
- Intake — Screened
- Discharge — 1/4" MNPT
- Housing — Glass-filled polyester
- Cover — Glass-filled polyester
- Volute — Nylon
- Impeller — Nylon
- Shaft Seal — Viton[®]
- Screen — Polypropylene
- Electrical — 115V, 60HZ

Small submersible epoxy encapsulated pump for commercial, industrial and home use. Applications include statuary fountains, water displays, air conditioners, machine tool coolants, and many other applications where liquid must be transferred or recirculated. This compact 300 GPH pump features a 1/4" MNPT discharge, 12.2' shut-off head capability, screened inlet and a 6' power cord.

Little Giant Pump Co.

PE-2H SERIES

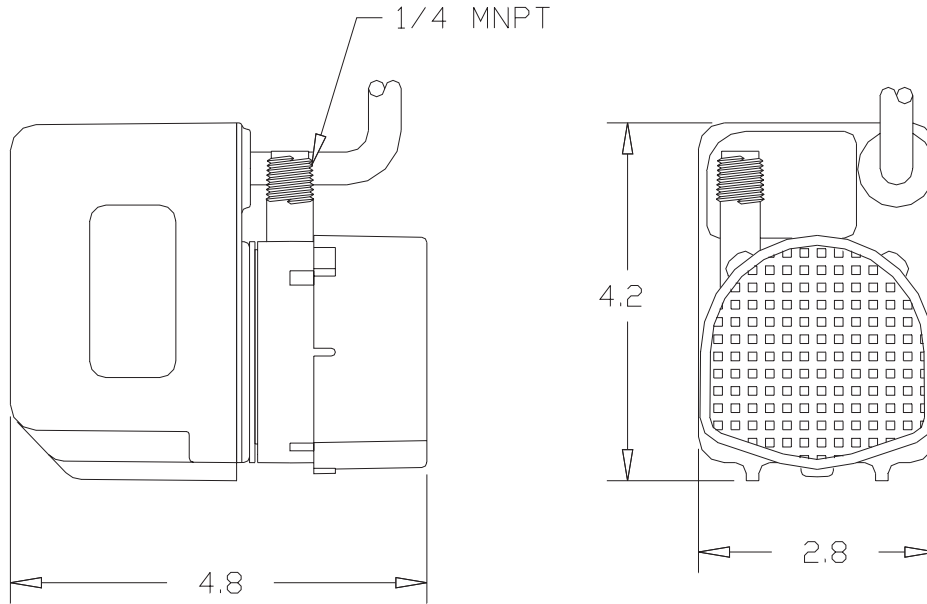

Specifications

Model No.	Item No.	Discharge		HP	Volts	Hertz	Amps	Watts	Performance (GPH @ Head)				Shut Off		Pwr. Cord (ft)	Weight (Lbs.)
		Size	Listing(s)						1'	3'	5'	10'	Feet	PSI		
PE-2H	518400	1/4" MNPT	UL/CSA	1/40	115	60	0.8	47	300	270	240	130	12.2	5.3	6	4.17

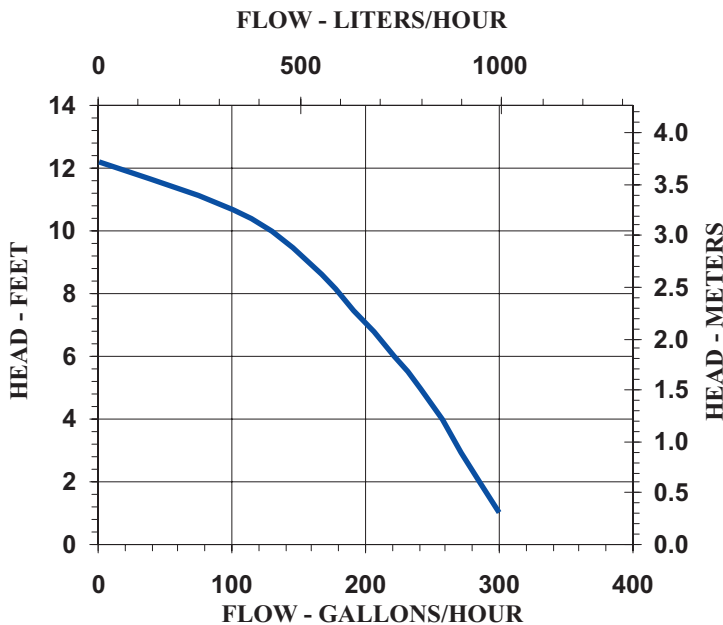

Replacement Parts

Volute	102332
Impeller	102703
Screen	102376
Gasket	102601

Little Giant Pump Co.
 PO Box 12010
 Okla. City, OK 73157
 Phone: 405.947.2511
 Fax: 405.228.1550
www.LittleGiantPump.com