

Little GIANT[®]

Pump Company

2E-N SERIES



Features

- Epoxy coated die-cast aluminum housing
- Oil-filled motor
- 11.8' maximum lift
- 100 watts
- 1/4" MNPT discharge
- Thermal overload protection
- For submersible use only

Construction

- Motor — 1/40 HP Oil Filled
- Intermittent Liquid Temp up to — 120° F
- Intake — Hooded/Screened
- Discharge — 1/4" MNPT
- Housing — Epoxy coated cast aluminum
- Cover — Epoxy coated cast aluminum
- Volute — Nylon
- Impeller — Nylon
- Shaft Seal — Nitrile
- Screen — Polypropylene

Small submersible oil-filled pump with epoxy coated cast aluminum housing. For commercial, industrial and home applications including statuary fountains, water displays, air conditioners, machine tool coolants, and many other applications where liquid must be transferred or recirculated. This compact 300 GPH pump features a 1/4" MNPT discharge, 11.8' shut-off head capability, and screened inlet.

Little Giant Pump Co.

2E-N SERIES

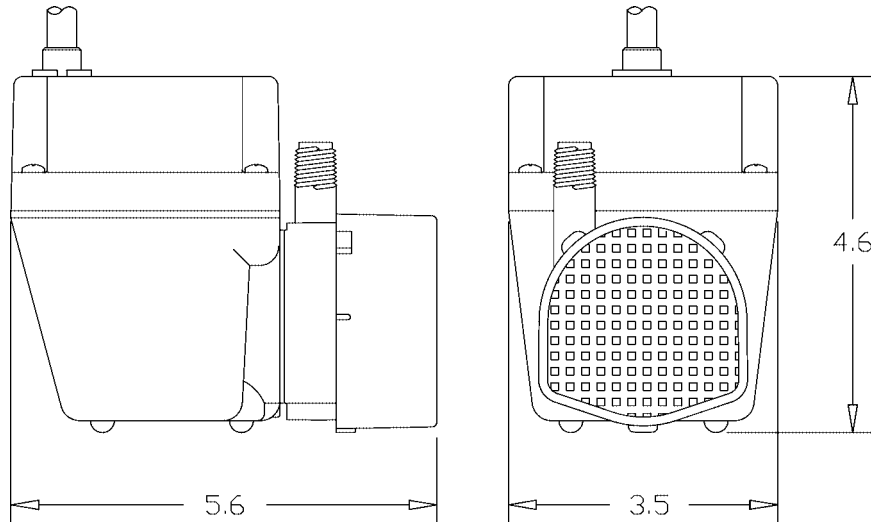

Specifications

Model No.	Item No.	Discharge		HP	Volts	Hertz	Amps	Watts	Performance (GPH @ Head)				Shut Off		Pwr. Cord (ft)	Weight (Lbs.)
		Size	Listing(s)						1'	3'	5'	10'	Feet	PSI		
2E-N	502103	1/4" MNPT	UL	1/40	115	60	1.7	100	300	255	205	70	11.8	5.1	6	4.67
2E-NT	502186	1/4" MNPT	UL/CSA	1/40	115	60	1.7	100	300	255	205	70	11.8	5.1	10	5.00
2E-NY	502116	1/4" MNPT	UR	1/40	230	50/60	1.0/.85	100	300	255	205	70	11.8	5.1	12	5.17

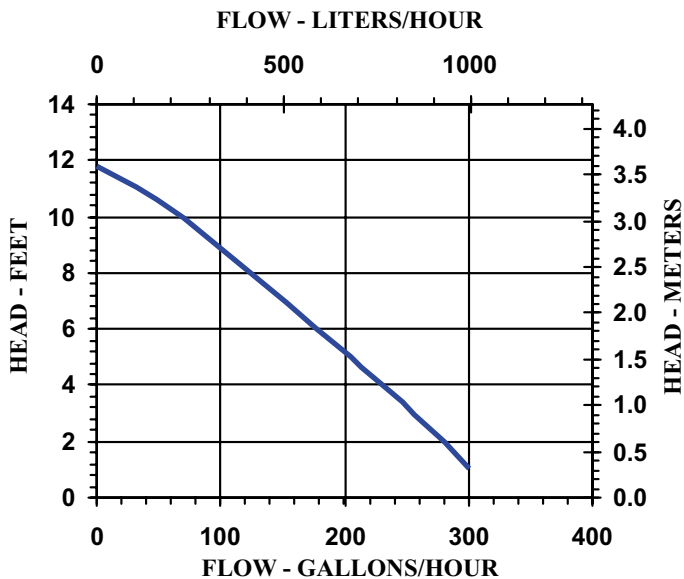

Replacement Parts

Volute	102333
Impeller	102470
Screen	102909
Gasket	102601

Little Giant Pump Co.
 PO Box 12010
 Okla. City, OK 73157
 Phone: 405.947.2511
 Fax: 405.228.1550
www.LittleGiantPump.com