

Little GIANT[®]

Pump Company

4E-34NR SERIES



Features

- Epoxy coated die-cast aluminum housing
- Oil-filled motor
- 24.5' maximum lift
- 210 watts
- 1/2" MNPT discharge
- Thermal overload protection
- For submersible use only

Construction

- Motor — 1/12 HP
- Intermittent Liquid Temp. up to — 120° F
- Intake — 3/4" FNPT
- Discharge — 1/2" MNPT
- Housing — Epoxy coated cast aluminum
- Cover — Epoxy coated cast aluminum
- Volute — Nylon
- Impeller — Nylon
- Shaft Seal — Viton[®]
- Screen — Polypropylene

Small submersible oil-filled pump with epoxy coated cast aluminum housing. For commercial, industrial and home applications including statuary fountains, water displays, air conditioners, machine tool coolants, and many other applications where liquid must be transferred or recirculated. This compact 810 GPH pump features a 1/2" MNPT discharge, 24.5' shut-off head capability, and screened inlet.

Little Giant Pump Co.

4E-34NR SERIES

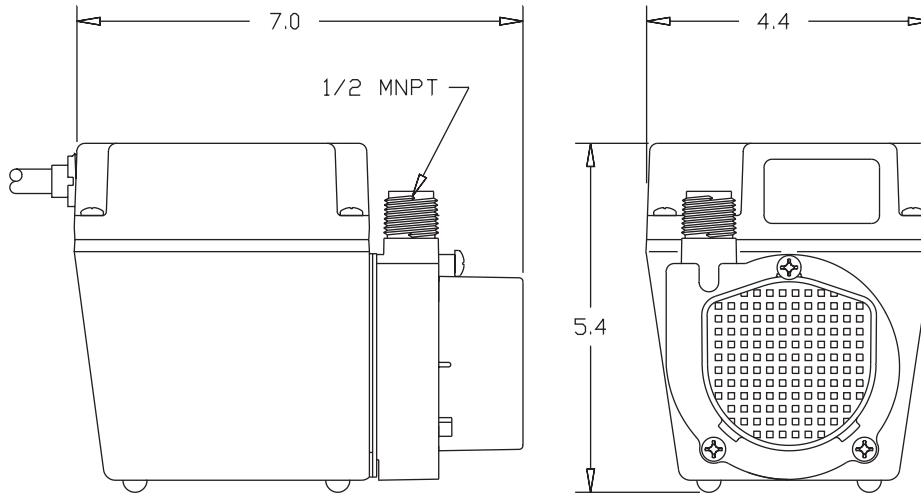

Specifications

Model No.	Item No.	Discharge	Intake	Listing(s)	HP	Volts	Hertz	Amps	Watts	Performance (GPH @ Head)					Shut Off		Pwr. Cord (ft)	Weight (Lbs.)
										1'	3'	5'	10'	20'	Feet	PSI		
4E-34NR	504203	1/2" MNPT	3/4" FNPT	UL	1/12	115	60	3.5	210	810	790	745	613	173	24.5	10.6	6	8.50
4E-34NRY	504216	1/2" MNPT	3/4" FNPT	UR	1/12	230	50/60	1.7	210	810	790	745	613	173	24.5	10.6	12	8.50

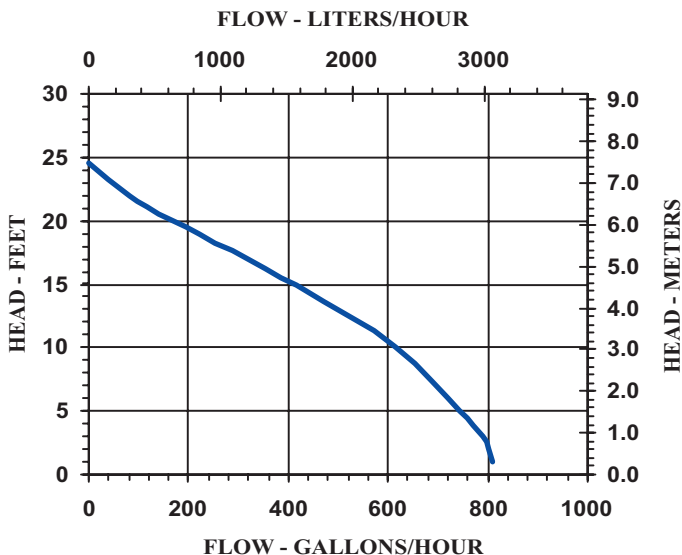

Replacement Parts

Volute	103334
Impeller	104435
Screen	102909
Gasket	103601

Little Giant Pump Co.

PO Box 12010
Okl. City, OK 73157

Phone: 405.947.2511
Fax: 405.228.1550

www.LittleGiantPump.com

Form 995112 —11/00