

Little GIANT[®]

Pump Company

5-MSP SERIES



Features

- Epoxy coated die-cast aluminum housing
- Oil-filled motor
- 26.3' maximum lift
- 380 watts
- 1" FNPT discharge
- Thermal overload protection
- For submersible use only

Construction

- Motor — 1/6 HP Oil Filled
- Intermittent Liquid Temp. up to — 120° F
- Intake — Screened
- Discharge — 1" FNPT
- Housing — Epoxy coated cast aluminum
- Cover — Epoxy coated cast aluminum
- Volute — Nylon
- Impeller — Nylon
- Shaft Seal — Viton[®]
- Screen — Nylon

Little Giant's most versatile portable utility pump with oil-filled motor and epoxy coated cast aluminum housing. For commercial, industrial and home applications including statuary fountains, water displays, air conditioners, machine tool coolants, and many other applications where liquid must be transferred or recirculated. Pumps down to 1/8". This 1200 GPH pump features a 1" FNPT discharge with garden hose adaptor, 26.3' shut-off head capability, and screened inlet.

Little Giant Pump Co.

5-MSP SERIES

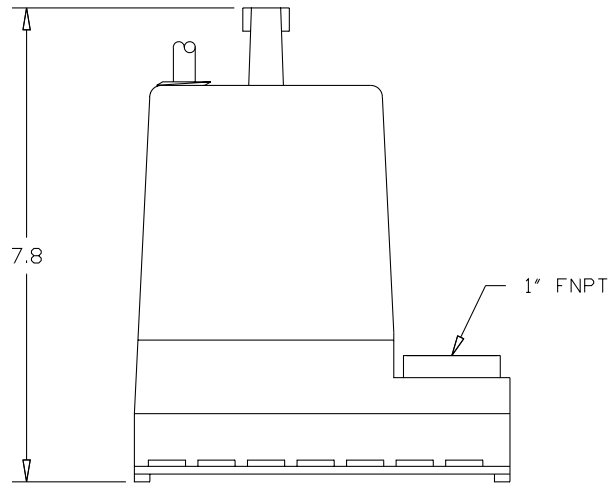
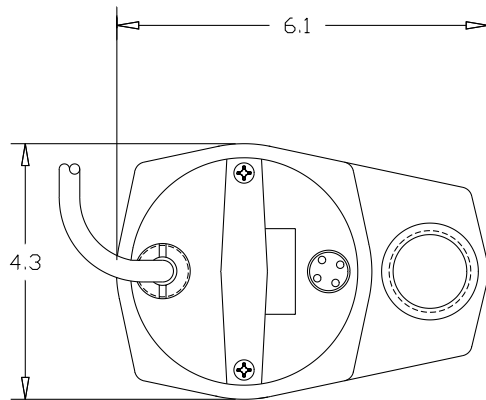

Specifications

Model No.	Item No.	Discharge	Intake	Listing(s)	HP	Volts	Hertz	Amps	Watts	Performance (GPH @ Head)					Shut Off		Pwr. Cord (ft)	Weight (Lbs.)
										1'	3'	5'	10'	20'	Feet	PSI		
5-MSP	505000	1" FNPT	Screened	UL	1/6	115	60	5.0	380	1200	1170	1100	1000	520	26.3	11.4	10	8.25
5-MSP	505086	1" FNPT	Screened	UL/CSA	1/6	115	60	5.0	380	1200	1170	1100	1000	520	26.3	11.4	10	8.25
5-MSP	505176	1" FNPT	Screened	UL/CSA	1/6	115	60	5.0	380	1200	1170	1100	1000	520	26.3	11.4	18	8.50
5-MSP	505025	1" FNPT	Screened	UL	1/6	115	60	5.0	380	1200	1170	1100	1000	520	26.3	11.4	25	8.75
5-MSP	505500	1" FNPT	Screened		1/6	127	60	5.0	380	1200	1170	1100	1000	520	26.3	11.4	10	8.25
5-MSP	505501	1" FNPT	Screened		1/6	127	60	5.0	380	1200	1170	1100	1000	520	26.3	11.4	18	8.50
5-MSP	505202	1" FNPT	Screened		1/6	230	60	2.5	380	1200	1170	1100	1000	520	26.3	11.4	12	8.25

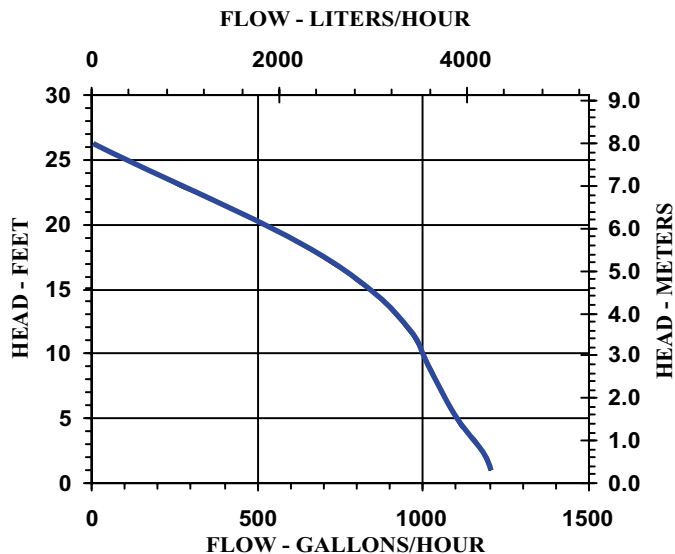

Replacement Parts

Volute	105200
Screen	105900
Impeller	105310
Handle	105911
Adapter (GH)	599030
Seal Ring	928024

Little Giant Pump Co.
 PO Box 12010
 Okla. City, OK 73157
 Phone: 405.947.2511
 Fax: 405.228.1550
www.LittleGiantPump.com