



Evergreen® • IM



# Installation Guide

[www.EvergreenDealer.com](http://www.EvergreenDealer.com)  
[www.theDealerToolbox.com](http://www.theDealerToolbox.com)

 genteq™



When Regal Beloit acquired General Electric's Commercial and HVACR Motors and Capacitors businesses in 2004, it also acquired the rights to use the GE brand during the transition. With this rebranding, the Genteq logo will begin replacing GE ECM, GE Commercial Motors and GE Capacitors logos on all branded products. For more information on the brand change, please visit [genteqmotors.com](http://genteqmotors.com)

1946 Cook Road  
Fort Wayne, IN 46818  
1-866-503-8566  
[www.theDealerToolbox.com](http://www.theDealerToolbox.com)

Evergreen® IM Installation Guide  
© Copyright 2008  
Regal Beloit Corporation

The information in this document is subject to change without notice.  
GTQ-8004 Rev 04/10

# Table of Contents

- Safety Considerations ..... 1
- Introduction ..... 2
- Application Guide ..... 3
- Motor Selection ..... 3
- Pre-Installation Notes ..... 4
- Installation Guide ..... 5-17
  - Mounting the Evergreen IM ..... 5-6
  - Electrical Connections ..... 7-17
    - High Voltage Power ..... 7-8
    - High Voltage Signal ..... 9-12
    - Low Voltage Signal ..... 13-14
    - Special Applications ..... 15
    - Continuous Fan Operation ..... 16
    - Final Notes ..... 17
- Airflow Tests ..... 18-22
- Sequence of Operation ..... 23-28
- Maintenance ..... 28
- Troubleshooting Guidelines ..... 29-34
- Installation Worksheet..... 35
- Contractor Hotline ..... Back page

**Please read the entire instruction manual  
before starting the installation.**

# Safety Considerations

The following definitions are used as safety considerations on the Evergreen IM motor and in this manual. Please read and observe all of these safety concerns.

## SAFETY SYMBOLS

 **WARNING** Warning indicates a hazardous situation which, if not avoided, could result in death or serious injury.

 **CAUTION** Caution indicates a hazardous situation which, if not avoided, could result in minor or moderate injury.

Installation and service of this motor should be attempted only by trained service technicians familiar with the Evergreen instructions and training manual.

This motor should be installed in accordance with accepted practices and installation instructions, and in compliance with all national and local codes.

### **WARNING**

The Evergreen IM is a multi-purpose replacement indoor blower motor. Proper wiring is critical to provide proper operation and maintain the proper operation of all safeties built into the HVAC System.

### **WARNING**

Always disconnect the main power from the unit being serviced before making any wiring connections to the Evergreen IM. It is also a good practice to confirm that the power is off with a meter.

### **WARNING**

The Evergreen IM is a multi-volt capable motor. Read all instructions and install the proper jumper for the line voltage application before applying power to this motor.

### **CAUTION**

Use of the wires provided in this kit is recommended. Should additional wires be needed, use equivalent size wire gauge and rated insulation.

### **WARNING**

Improper installation, adjustment, alternation, service, maintenance, or use can cause explosion, fire, electrical shock, or other conditions which may cause personal injury, death, or property damage. Consult a qualified installer, service agency, or your distributor or branch for information or assistance. The qualified installer or agency must use the supplied or recommended parts when installing or servicing this product.

# Introduction

The Evergreen IM is an ECM (Electronically Commutated Motor) designed to replace an existing PSC (Permanent Split Capacitor), direct drive, indoor blower motor. It is constructed with more than 20 years of proven ECM technology and reliability.

This installation/service manual enables a qualified technician to install, service, repair and maintain the Evergreen IM motor. This manual is to be left near the HVAC system for future reference. Due to the advanced multi-function of this motor it is highly recommend that you read the entire manual before beginning any job to make sure it is the correct motor for the HVAC System it is being applied to.

This unique ECM motor will operate and connect to the HVAC systems controls much differently than the replaced PSC motor. For proper, safe and efficient operation please read the entire manual before attempting any wiring connections.

When properly installed the Evergreen IM will maintain the sequence of operation and safety operations of the HVAC System.

On page 35 of this manual is an Installation Worksheet provided to write down all the critical information for the selection, installation and airflow testing.

Included with this motor for help with installation and wiring connections are the following:

- 115VAC white jumper
- Optional Y-adaptor
- 230VAC yellow jumper (installed on motor)
- HVAC System ID Label

# Application Guide

The Evergreen IM is designed for use on the following types of HVAC systems:

- Direct Drive, 115 or 230VAC Motor Systems
- Clock-wise (CW) or Counter Clock-wise (CCW) rotation
- Residential Split and Packaged Systems
- Air Conditioning or Heat Pump Systems
- Natural Gas, Propane and Oil Heat Furnaces
- Dual Fuel Systems
- Hot water coil and Geothermal air handlers

**DO NOT** use this motor on any “twinned” furnace or air handler systems.

**DO NOT** use this motor to replace any existing ECM other than a direct replacement of an Evergreen IM.

## Motor Selection

Confirm the motor is applicable to the HVAC System using the Application Guide above.

Confirm the motor being replaced is a direct drive indoor blower motor operating at 115 or 230VAC. This is a dual voltage motor.

This motor will operate Clock-wise (CW) or Counter Clock-wise (CCW) rotation automatically with its built-in Rotation Sensing feature. For more information see the Sequence of Operation section on page 23.

Check off the HVAC systems existing PSC motor horse power (Hp) and HVAC equipment size to determine the Evergreen IM sizing. Use the motor that best matches the HVAC system sizing.

1/5 - 1/2 Hp	<input type="checkbox"/>	} 1/2 Hp Evergreen IM
1.5 - 3 Ton	<input type="checkbox"/>	
40 - 95k BTUH	<input type="checkbox"/>	
1/2 - 1 Hp	<input type="checkbox"/>	} 1 Hp Evergreen IM
3.5 - 5 Ton	<input type="checkbox"/>	
100 - 150k BTUH	<input type="checkbox"/>	

# Pre-Installation Notes

Before removing the existing motor, check off the existing speed selections, in each mode of operation, in the spaces below. If the motor is operational, also record the Total External Static Pressure (TESP) and/or the Temperature Rise (TR) in each mode of operation. This information will help select the new motor speeds.

## HEAT PUMP SYSTEMS

Cooling/Heating Speed Hi\_\_\_ MHi\_\_\_ MLo\_\_\_ Lo\_\_\_ TESP\_\_\_

Cooling/Heating Speed Hi\_\_\_ MHi\_\_\_ MLo\_\_\_ Lo\_\_\_ TESP\_\_\_  
(1st Stage)

Emer. Heat Speed Hi\_\_\_ MHi\_\_\_ MLo\_\_\_ Lo\_\_\_ TESP\_\_\_ TR\_\_\_

Furnace Heat Speed Hi\_\_\_ MHi\_\_\_ MLo\_\_\_ Lo\_\_\_

Furnace Heat Speed Hi\_\_\_ MHi\_\_\_ MLo\_\_\_ Lo\_\_\_  
(1st Stage)

## AIR CONDITIONING AND/OR GAS, PROPANE OR OIL HEATING SYSTEMS

Cooling Speed Hi\_\_\_ MHi\_\_\_ MLo\_\_\_ Lo\_\_\_ TESP\_\_\_

Cooling Speed Hi\_\_\_ MHi\_\_\_ MLo\_\_\_ Lo\_\_\_ TESP\_\_\_  
(1st Stage)

Heating Speed Hi\_\_\_ MHi\_\_\_ MLo\_\_\_ Lo\_\_\_

Heating Speed Hi\_\_\_ MHi\_\_\_ MLo\_\_\_ Lo\_\_\_  
(1st Stage)

**NOTE:** The HVAC Systems fan control connections, where the existing PSC motor is connected, will be used to operate the Evergreen IM. Make note of the terminals that the old motor connected to for heating and/or cooling operation before removing the motor wires.

# Installation Guide

## MOUNTING THE EVERGREEN IM

### WARNING

Always disconnect the main power from the unit being serviced before making any wiring connections to the Evergreen IM. It is also a good practice to confirm that the power is off with a meter.

Remove the blower section from the HVAC system. Remove the existing PSC motor from the blower section. Properly dispose of the motor and the run capacitor. The Evergreen IM motor does not require a run capacitor.

The frame size of the Evergreen IM motor is NEMA 48 frame. This is the most common frame size for indoor blower motors. If the original motor has the same frame size, the original mounting bracket should work on the Evergreen IM. The Evergreen IM requires a belly band style mounting bracket. The original mounting bracket can be used as long as it is belly band style with no special bolts or bearing mounts. **Torsion flex brackets can be used on the ½ Hp motor only. They are not approved for the 1 Hp motor due to noise and longevity.**

If the mounting bracket must be replaced, selecting one with the same mounting pattern on the blower housing will save drilling new holes in the blower section.

The belly band must fit the new motor properly. It should be tight enough to prevent the motor from shifting on start-up and not cover any vents. On ECM motors the belly band must not be placed over the motor control section.

**NOTE:** when attaching the bellyband mount, make sure it is not located in the “Keep Out Area” area.

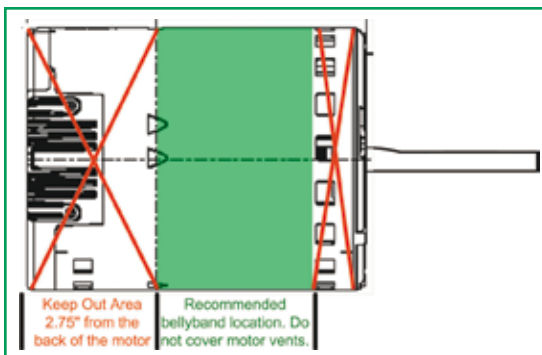



## MOUNTING THE EVERGREEN IM (CONTINUED)

If a new motor mount is required and the legs do not line up with the original holes in the blower housing, it is required to use a bolt with either a lock washer and nut or a locking nut through the new drilled hole(s).



Self tapping or sheet metal screws are not a sufficient long term installation when a new hole is drilled through the thin wall of the blower housing.



When positioning the legs of the bellyband on the motor, make sure that once the motor is mounted into the blower section, the wires come out towards the bottom of the motor as installed in the air handler. This will ensure that a proper drip loop can be made with the signal and power lines.

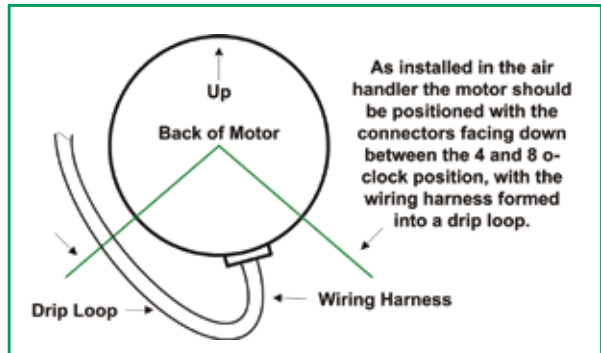

The blower wheel should be centered in the blower housing. The wheel should also not be resting up against the motor bearing housing. If this is not possible while centering the wheel the motor should be adjusted in the belly band. If the blower wheel is dirty, it should be cleaned.



The blower wheel hub locking bolt should be secured to the motor shaft on the flat portion of the shaft, after the wheel has been centered in the blower housing.



Re-install the blower section in the HVAC system and proceed to the next page to make the electrical connections.

## ELECTRICAL CONNECTIONS

### HIGH VOLTAGE POWER CONNECTIONS

- The Evergreen IM is connected to line (High) voltage power at ALL TIMES.
- Do not connect the High Voltage Power leads of the Evergreen IM motor to any relays or switched circuit board terminals.
- **If a door switch is present, wire after the switch so power will be disconnected when the door is removed for service or maintenance.**
- If the HVAC system has multiple line voltage circuits (typically on systems with multiple heat strips), connect the Evergreen IM to the same circuit that powered the main/fan control board or fan relay for the original motor.
- This motor is capable of operation from 115 or 230VAC line voltage with the proper application of the voltage jumper.

**Step 1:** DO NOT CONNECT OR DISCONNECT ANY PLUGS OR JUMPERS WITH LINE VOLTAGE POWER CONNECTED OR APPLIED TO THE HARNESS. Install the proper voltage jumper for the system the motor will be installed in. For 230VAC applications, the yellow jumper is pre-installed in the motor. For 115VAC applications, remove the yellow jumper and install the supplied white jumper. Then connect the 5-pin plug with the alignment fin facing away from the jumper. The fin and the motor connector block are both labeled 1-5 for proper orientation. Finally connect the 4-pin plug. This plug is keyed for proper orientation. The larger end of the plug with the larger connector goes to L1 on the motor. Make sure the jumper and both plugs are firmly inserted into the motor. See the examples below.

230VAC System  
Configuration  
(Yellow Jumper)



115VAC System  
Configuration  
(White Jumper)



# ELECTRICAL CONNECTIONS

## HIGH VOLTAGE POWER CONNECTIONS (CONTINUED)

**Step 2:** Cut the High Voltage POWER harness to the length needed (leave a little extra) to reach the desired line voltage connection point.

**Step 3:** Strip the insulation back to connect bare wires or install terminals as needed.

### ⚠ WARNING

Always disconnect the main power from the unit being serviced before making any wiring connections to the Evergreen IM. It is also a good practice to confirm that the power is off with a meter.

**Step 4:** Connect the Black L1 wire to Line Voltage L1 on either 115 or 230VAC systems.

**Step 5:** Connect the White L2/N to Neutral on 115VAC systems or Line Voltage L2 on 230VAC systems.

**Step 6:** Connect the Green w/Yellow stripe ground wire that is pre-connected to the silver control end of the motor to any cabinet ground within reach. The blower section is an acceptable ground. Confirm that the HVAC system cabinet is grounded.

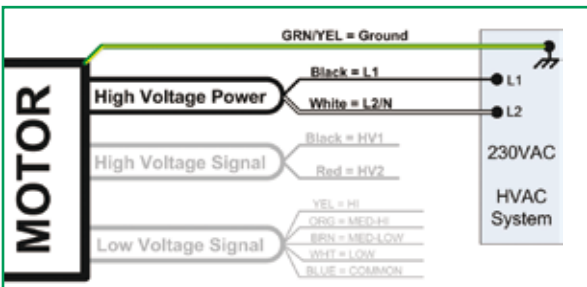
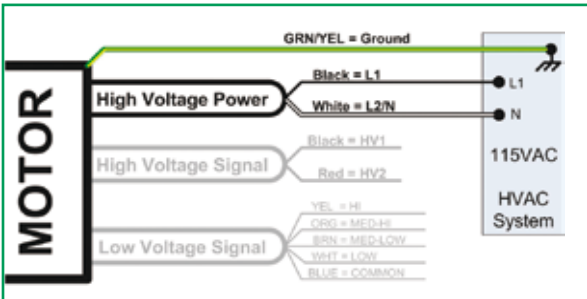

**Note:** On 230VAC systems, L1 from the motor must be connected to the same line voltage supplied to the HVAC system fan control or fan relay.

# ELECTRICAL CONNECTIONS

## HIGH VOLTAGE SIGNAL CONNECTIONS

- The High Voltage SIGNAL connections communication tell the Evergreen IM when to turn on and off according to the HVAC systems original fan control or fan relay outputs. This maintains the operational integrity of the HVAC System.
- These connections will also determine the output horse power (Hp) of the Evergreen IM. The output Hp of the Evergreen IM should be set to match the Hp rating of the PSC motor that was removed.
- Due to the multi-purpose application of this motor it would be impossible to provide a wiring diagram for each unique HVAC System it could be used on. The diagrams on the following pages will cover the most common HVAC system high voltage fan operation outputs.
- Depending on the HVAC System, there may be only one or up to four individual fan control connections necessary. These can be identified using the existing HVAC Systems wiring diagram or following where the replaced motor speed(s) were connected.

**Step 1:** Identify the horse power (Hp) rating of the replaced PSC motor. Use the following chart to determine which High Voltage SIGNAL (HV) connection(s) to use.

1/2 Hp Motor	— [	HV1 & HV2 = 1/2 - 1/3 Hp operation
		HV1 = 1/3 - 1/4 Hp operation
		HV2 = 1/4 - 1/5 Hp operation

1 Hp Motor	— [	HV1 & HV2 = 3/4 - 1Hp operation
		HV1 = 3/4 - 1/2 Hp operation
		HV2 = 1/2 Hp operation

# ELECTRICAL CONNECTIONS

## HIGH VOLTAGE SIGNAL CONNECTIONS (CONTINUED)

**Step 2:** Prepare the High Voltage SIGNAL (HV) connections of the Evergreen IM motor to provide the desired horse power output using the diagram below. Configure the output of the Evergreen IM to match the horse power rating of the PSC motor it is replacing.

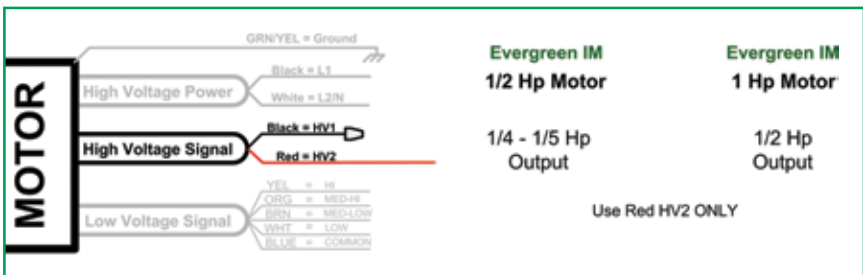
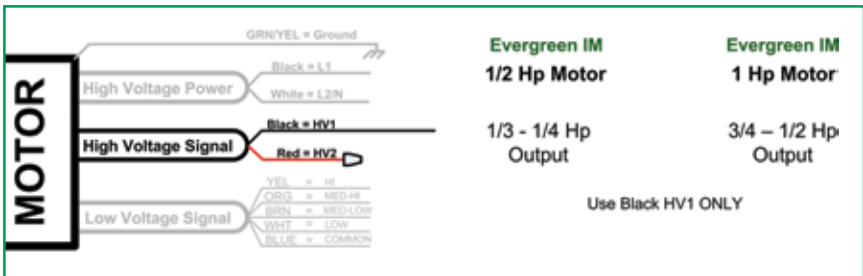
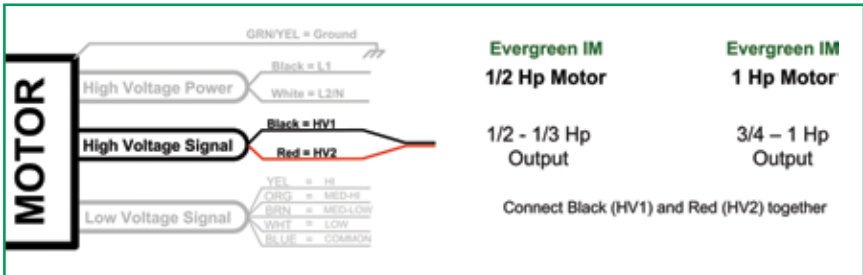

☐ This symbol represents a wire nut

# ELECTRICAL CONNECTIONS

## HIGH VOLTAGE SIGNAL CONNECTIONS (CONTINUED)

**Step 3:** Identify where on the HVAC system the PSC motor speed(s) were connected. These connections could be on a main circuit board, a separate fan control circuit board, or individual fan relay or fan switch. All of the connections previously used by the PSC motor speeds except Neutral will now be connected/wired together. This will allow the Evergreen motor to receive 115VAC communication from all HVAC system demands. **NOTE: None of these connections will be energized at the same time by the HVAC system due to the fact that a PSC motor cannot be energized on more than one speed at a time. These 115VAC fan outputs will now become communication only for the Evergreen motor.**

For heating or cooling only systems there should be only one connection. For single or two stage heat and/or cool systems see the diagrams below.

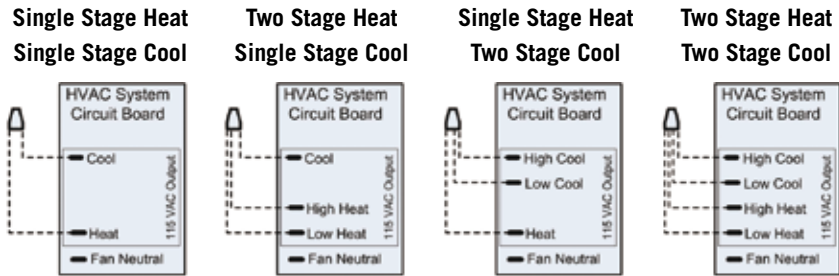

--- The dashed lines represent new field wiring added after the PSC motor wiring has been removed  
 ⚡ This symbol represents a wire nut

For systems that energize the heat or cool taps for constant fan, no other wiring is needed for constant fan operation from the thermostat.

If the circuit board also uses a Constant Fan tap typically labeled (CF), combine this tap with the previous connections for constant fan operation. For systems that energize the (CF) tap from a thermostat (G) demand no other wiring is needed for constant fan operation from the thermostat. See the example:

### Single Stage Heat Single Stage Cool w/CF (constant fan)

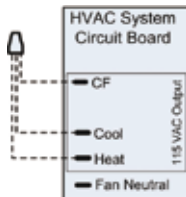

**NOTE: In rare cases the (CF) tap on the circuit board is always powered when there is no heat or cool demand. In this case the customer has no control over the constant fan operation from the thermostat.**

# ELECTRICAL CONNECTIONS

## HIGH VOLTAGE SIGNAL CONNECTIONS (CONTINUED)

**Step 4:** Connect the selected High Voltage SIGNAL (HV) connection(s) from the motor in Step 2 to the combined fan output connections on the HVAC system in Step 3. See examples below.

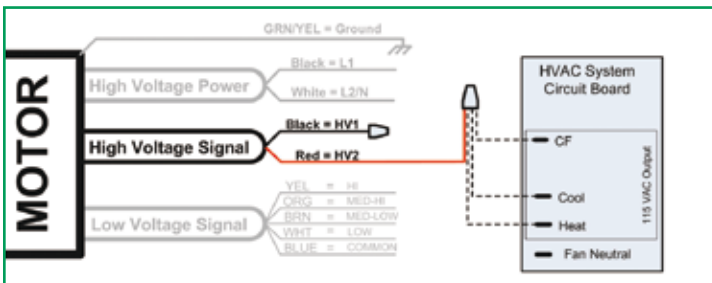
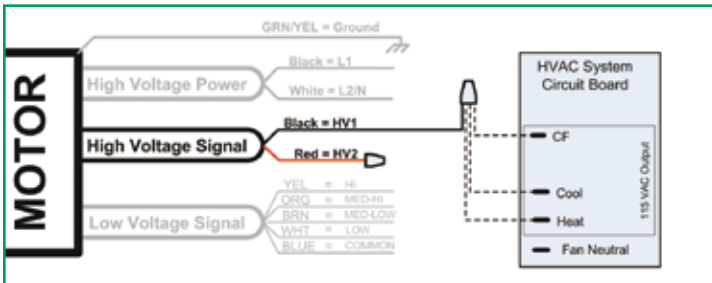
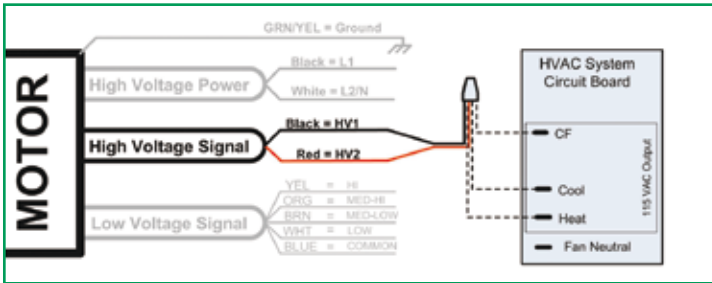

--- The dashed lines represent new field wiring added after the PSC motor wiring has been removed

△ This symbol represents a wire nut

## ELECTRICAL CONNECTIONS

### LOW VOLTAGE SIGNAL CONNECTIONS

#### WARNING

DO NOT connect the Low Voltage SIGNAL (speed) connections to the existing PSC motor connections on the HVAC system. Any voltage above 30VAC connected to these terminals will cause irreparable damage to the motor.

- The Evergreen IM is unique in how it operates. Unlike a PSC motor, the Evergreen IM motor operation (speed) is selected by the low voltage communication inputs powered directly from the HVAC system thermostat lines.
- Do not remove the existing thermostat lines connected to the HVAC system from the thermostat. The Evergreen IM is wired in parallel to these connections. The lines from the thermostat still need to be connected to the HVAC system for correct operation.
- **NOTE:** There can be more than one Low Voltage SIGNAL (speed) tap powered on the Evergreen IM motor at the same time. Unlike PSC motors, the Evergreen IM will operate the highest speed tap that has low voltage communication. For more information, see the Sequence Of Operation section on page 23.

**Step 1:** Cut the Low Voltage SIGNAL harness to the length needed (leave a little extra) to reach the HVAC system thermostat connections.

**Step 2:** Strip the insulation back to connect bare wire or install terminals as needed to the appropriate speed selections determined below.

**Step 3:** Connect the Low Voltage SIGNAL wire COMMON to the 24VAC common (C) thermostat terminal or 24VAC common side of the transformer on the HVAC System. Make sure that this line is not connected to the side of the transformer connected to the thermostat 24VAC (R). If it is connected to the (R) high side of the transformer, the motor will not operate. See the diagram on the next page.

**Step 4:** Connect the desired speed(s), Low Voltage SIGNAL wire(s) to the appropriate HVAC System thermostat connection(s). Use the same speed(s) for the heating and/or cooling demand(s) as the replaced motor. Reference the PRE-INSTALLATION NOTES on page 4.

See the diagram on the next page.



# ELECTRICAL CONNECTIONS

## LOW VOLTAGE SIGNAL CONNECTIONS (CONTINUED)

Most HVAC systems use the same terminal designations for their thermostat demands. However there are variations. If the terminal designations in the HVAC system being connected to are different than the ones used in our diagrams, match them up to the operation of our generic listing below.

### Air Conditioning Systems with or without Electric Strip Heat

- Y — Call for cooling on single stage systems
- Y<sub>1</sub> — Call for first stage cooling on two stage systems
- Y<sub>2</sub> — Call for second stage cooling on two stage systems
- W — Call for heating (electric strips)

### Heat Pump Systems with or without Electric Strip Heat

- Y — Call for heating and cooling (operates the outdoor unit contactor)
- W<sub>2</sub> — Call for Emergency Heat

### Gas, Propane or Oil Heat Systems

- W — Call for heating on single stage systems
- W<sub>1</sub> — Call for first stage heating on two stage systems
- W<sub>2</sub> — Call for second stage heating on two stage systems

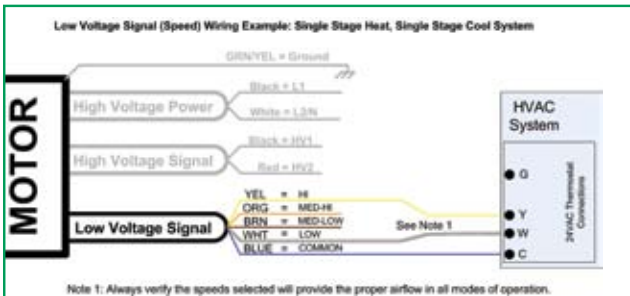

**The (G) continuous fan connection from the thermostat is not required on the Evergreen IM for continuous fan operation.** A special high efficiency fan speed will be energized automatically if constant fan is energized from the thermostat through the High Voltage SIGNAL connection(s). If continuous fan operation is desired at a higher airflow, see the Special Applications section on page 16.

See the next page for any SPECIAL APPLICATIONS and/or continue with the FINAL ELECTRICAL CONNECTION NOTES on page 17.

# ELECTRICAL CONNECTIONS

## SPECIAL APPLICATIONS

If the HVAC System this motor is applied to uses a separate speed for each heating and/or cooling demand including two-stage systems, this page is not needed.

### Systems that require the same speed for heating and/or cooling demands.

For Example:

- Heat Pump Systems with or without emergency electric strip heat.
- Air Conditioning Systems with electric heat.
- Large furnaces connected to a small air conditioning or heat pump.
- Systems with multiple stages and overlapping airflow requirements.

To allow the motor to operate at the same speed from two different thermostat demands, the special **Y-adapter** included in the box must be used. **DO NOT attempt to use any other method to wire two thermostat lines to the same speed.** The Y-adapter is specially designed for this application to prevent voltage feedback, and the operation of multiple demands at the same time.

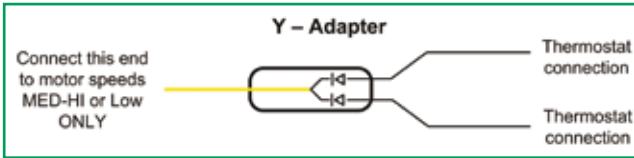

**Only the MED-HI and LOW speeds can be used with the Y-adapter. If HI or MED-LOW is found to be the required airflow for two system demands another speed will have to be used for one of the demands, or the Evergreen IM should not be applied to that system.** In most cases the speeds of the Evergreen IM are close enough in airflow range to select another speed for one of the demands.

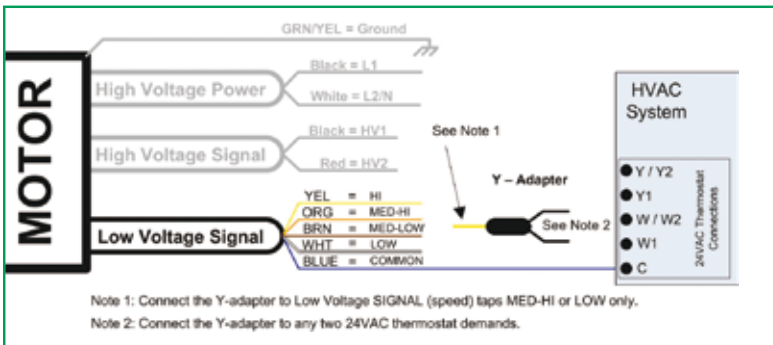

# ELECTRICAL CONNECTIONS

## CONTINUOUS FAN OPERATION

### High Efficiency Constant Fan Operation

The Evergreen IM will automatically operate a fixed high efficiency low constant fan airflow without a (G) fan connection to the Low Voltage SIGNAL (speed) taps. When the HVAC System receives a 24VAC (G) command from the thermostat to the fan controls, they will send 115VAC to the High Voltage SIGNAL connection(s). If the motor receives voltage on the High Voltage SIGNAL connection(s) with no voltage on the Low Voltage SIGNAL connections, the motor will operate at the special high efficiency low constant fan airflow automatically. See the Sequence of Operation section on page 28 for more information.

### Increasing Constant Fan Airflow

If more airflow is desired during constant fan operation there are two options.

**Option 1:** Connect any of the Low Voltage SIGNAL (speed) taps on the motor not being used by a heating or cooling demand to the 24VAC constant fan (G) thermostat demand.

**Option 2:** If the speed desired for constant fan is currently being used by a heating or cooling demand, use the special Y-adapter to connect any 24VAC thermostat demand and the 24VAC constant fan (G) thermostat demand to the same motor speed. **Only the MED-HI and LOW speeds can be used with the Y-adapter. If HI or MED-LOW is currently being used by a heating or cooling thermostat demand, another speed will have to be used for the 24VAC constant fan (G) thermostat demand.**

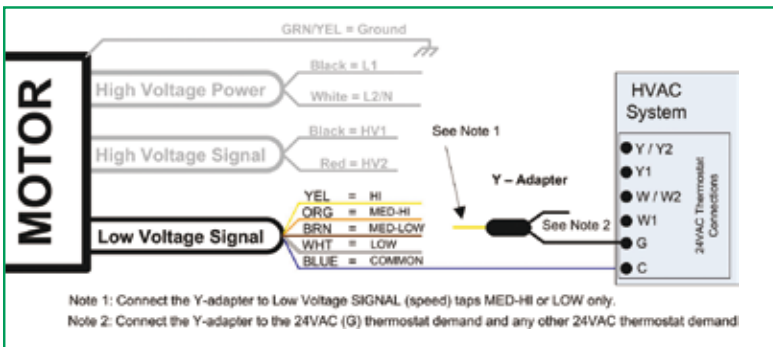

# ELECTRICAL CONNECTIONS

## FINAL NOTES

When finished connecting all of the Evergreen IM wires to the system, create the recommended drip loop, and assure it will not interfere with the blower wheel or other system wiring.

It is ok to leave extra wire, especially the unused speeds. Tie them to the harness for future use if needed. Even though the extra speed and High Voltage SIGNAL wires will have no voltage or current on them, it is a good practice to wire nut and tape these unused leads.

**INSTALL THE SYSTEM ID LABEL on the HVAC system near the existing wiring diagram and enter the Evergreen IM data.** Record the Horse Power (Hp) of the motor and the Date of Installation for future reference if needed. The motors Hp rating can be found on the label located on the box.

**ALWAYS verify the HVAC System operation in all demand modes applicable, heating, cooling and continuous fan.**

**Note: On 230VAC systems, if the motor does not run after all High and Low Voltage connections have been completed, reverse the High Voltage Power L1 and L2 connection from the motor.**

**ALWAYS verify the airflow in all demand modes by following the instructions in the next section on "Airflow Tests".**

Genteq is committed to helping with any special wiring or application questions. We have provided more example wiring diagrams if needed on our website at [www.EvergreenDealer.com](http://www.EvergreenDealer.com). If immediate assistance is required you may contact technical support on the **Evergreen Contractor Hotline at 1-866-503-8566**.

## AIRFLOW TESTS

After installing the Evergreen IM motor it is important to verify that the speed tap(s) selected will provide the proper airflow in all modes of operation for maximum performance, comfort, capacity and safe operation.

Before checking the airflow all filters should be cleaned or replaced. All grilles, balancing dampers and registers should also be clear and open.

### Recommended Set-up

Confirm airflow is matched to the systems performance requirements:

- Measure airflow with industry accepted instruments.
- Adjust the temperature rise on all fossil fuel heating systems to meet the OEM data plate specifications.
- Adjust the speed selections to achieve the design CFM (Cubic Feet per Minute) per ton of cooling.

Airflow and temperature measurements are often inaccurate without traversing the measured area. This applies to measurements taken inside the duct and at the return grille and supply registers. A traverse is typically 5 or more readings across the area of the airflow measurement. To find the average, add all readings together and divide by the number of readings taken.

Measuring the Total External Static Pressure (TESP) cannot be used to determine airflow with the HVAC System manufacturer's chart since those charts were not designed with the Evergreen IM motor.

However, most manufacturers rate their systems operation up to a maximum of .8 – 1.0 inches of water column. If the TESP is higher than the manufacturer's recommendation for that system, the airflow issues must be corrected.

**The Evergreen IM will not compensate for severe airflow restrictions.**

## AIRLOW TESTS (CONTINUED)

### Gas, Propane and Oil Heating Systems

#### WARNING

All Natural Gas, Propane, and Oil Heat Systems must be operated, tested and adjusted to confirm the Manifold Gas Pressure and Temperature Rise meet the values listed on the manufacturer's data plate.

Confirm system operation by operating the furnace (in both first and second stage on two stage furnaces) and measuring the Temperature Rise. The Temperature Rise should fall within the required values supplied on the HVAC Systems manufacturer data plate.

- Gas pressure should be set to the value listed on the HVAC Systems data plate.
- System should be at operating temperature (Steady State Condition) before taking temperature readings. The typically accepted time frame is 15 minutes or until the temperature rise and/or stack temperature has stabilized.
- If the temperature rise does not fall within the values listed on the HVAC Systems data plate, adjust the Low Voltage SIGNAL (speed) tap connected to the 24VAC thermostat heating demand up or down and take the readings again. Repeat as needed to attain the proper temperature rise.

An operating temperature rise that is lower than the manufacturer's recommendation can cause increased heat exchanger condensation. An operating temperature rise that is higher than the manufacturer's recommendation can cause system failure on high limit. Both of these situations can decrease the life of the heat exchanger.

It is highly recommended that a Carbon Monoxide (CO) measurement be taken on all fossil fuel furnaces at the conclusion of all service calls. Below is a listing of recommended levels of CO in the flue gas and in the home.

#### **AGA (American Gas Association) (1-2008)**

#### **ANSI Standard (American National Standards Institute) (1-2008)**

200ppm Air-Free = maximum allowed from an unvented space heater

400ppm Air-Free = maximum allowed in vented appliances flue gas

800ppm Air-Free = maximum allowed from unvented gas ovens

According to the EPA, no standards for CO have been agreed upon for indoor air. The U.S. National Ambient Air Quality Standards for outdoor air are 9ppm for 8 hours, and 35ppm for 1 hour. Any CO level found in a home that is higher than the outdoor reading should be investigated.

## AIRLOW TESTS (CONTINUED)

### Measuring Temperature Rise

Temperature rise should be measured as close as possible to the HVAC system in the return air inlet and in the supply out of the line of site of the heat exchanger. The diagram below shows an example of an up flow system and the recommended measuring points. Down flow (counter flow) and horizontal flow systems follow the same parameters.

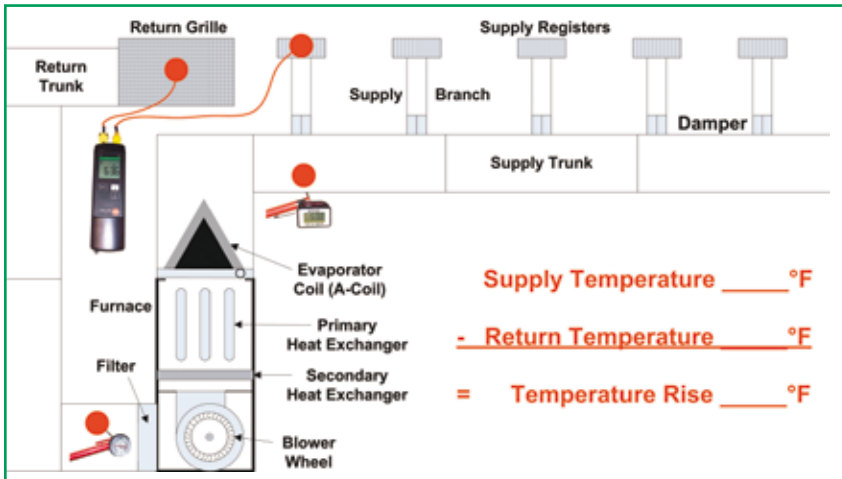

If access to the ductwork close to the furnace is not possible, use the closest return grille and supply register. Analog or digital thermometers are accurate enough for these readings. Some dual temperature meters will automatically calculate the difference.

Temperature rise is calculated as the difference between the supply and return temperature readings.

- Increase blower speed to lower the temperature rise.
- Decrease the blower speed to increase the temperature rise.

Example:

If the manufacturer's data plate rating is for a 30 – 60 degrees Fahrenheit temperature rise, and the actual measured rise is 65 degrees, the blower speed will need to be increased. If the actual measured rise is 25 degrees, the blower speed will need to be decreased.

## AIRLOW TESTS (CONTINUED)

### Air Conditioning and Heat Pump Systems

These systems are designed to operate with a specified amount of airflow measured in Cubic Feet per Minute (CFM). Whenever possible use the manufacturer's literature as the specification of recommended airflow. For two stage systems, only the manufacturer's manual can provide the data for 1st Stage airflow requirements.

The typically recommended CFM per ton of single stage (or second stage on two stage systems) cooling is 400, where one ton of cooling equals 12,000BTUH rating on the manufacturer's data plate. If your region dictates a higher or lower CFM per ton, use that value.

There are many ways to measure the CFM. The HVAC System should be operating in the cooling mode with a dry evaporator coil. If the CFM measured does not meet the required CFM of the system, adjust the Low Voltage SIGNAL (speed) tap connected to the 24VAC thermostat demand up or down and take the readings again. Repeat as needed to attain the proper CFM.

### Velocity Method

$CFM = Velocity \times Area$

Velocity = Feet Per Minute (FPM)

Area = Square Feet

Square Feet = Square Inches divided by 144

Square Inches = Height x Width

- Measure the velocity of the air in a duct, multiplied by the cross sectional area of the duct (H x W) in square feet.
- Measure the velocity of the air entering a single main return grille, multiplied by the cross sectional free area of the grille. Remove the filter on filter grilles.

### Evaporator Coil Pressure Drop Charts

If available, the manufacturer's indoor coil pressure drop charts are also an effective way to measure airflow. Measure the static pressure drop across the indoor coil and adjust the speed of the motor until the pressure drop equals the desired airflow on the chart.



## AIRLOW TESTS (CONTINUED)

### Temperature Rise Method

#### Electric Strip Heat ONLY

This method requires the operation of the electric strips and the indoor blower motor only by setting the thermostat to call for heat (W) on air conditioning systems with electric strip heat or emergency heat (W<sub>2</sub>) on heat pump systems with electric strips.

**Step 1.** Operate only the electric strips and the indoor blower on the speed of choice for this measurement.

**Step 2.** Measure the voltage and total amperage of the electric strip(s) and the indoor fan. Do this at the main power supply in the HVAC system. If there are multiple circuits for multiple sets of strips, add the amperage from all the circuits together.

**Step 3.** Calculate the temperature rise of the system. See “Measuring Temperature Rise” on page 20 for help if needed. For the purpose of this formula, temperature rise is listed as TD (Temperature Difference).

**Step 4.** Using the numbers that you have calculated for the system, plug them into the formula below to calculate the system’s CFM.

$$CFM = \frac{BTUH}{TD \times 1.08} = \frac{\frac{\text{Volts} \times \text{Amps}}{\text{TD}} \times 3.4}{TD \times 1.08} = \frac{\text{CFM}}{\text{CFM}} \text{ CFM}$$

BTUH = Output BTU per hour  
 CFM = Cubic Feet per Minute  
 TD = Temperature Difference, Temperature Rise & ΔT

**Speed Tap Used**  
\_\_\_\_\_

The temperature rise method can be used on fossil fuel furnaces; however, the Output BTUH must be confirmed by either adjusting the manifold gas pressure to the specification on the manufacturer’s data plate, or clocking the meter to confirm Input BTUH meets the manufacturer’s data plate listing.

$$CFM = \frac{BTUH}{TD \times 1.08} = \frac{\text{BTUH}}{TD \times 1.08} = \frac{\text{CFM}}{\text{CFM}} \text{ CFM}$$

BTUH = Output BTU per hour  
 CFM = Cubic Feet per Minute  
 TD = Temperature Difference, Temperature Rise & ΔT

**Speed Tap Used**  
\_\_\_\_\_

## SEQUENCE OF OPERATION

When connected properly, the Evergreen IM will operate following the same sequence of operation as the replaced motor according to the HVAC Systems demands and delays.

Line voltage (115 or 230 VAC) is connected to the **High Voltage POWER** connections on the motor at all times. This voltage powers the microprocessor and the controls that drive the motor. However, the motor will only be driven when there is a communication demand on the Low Voltage and/or High Voltage Signal connections.

The **Low Voltage SIGNAL** connections determine what speed the motor will operate at. This voltage alone cannot operate the motor. It can only communicate to the motor what level (speed) of operation is desired.

The **High Voltage SIGNAL** connections are the on/off communication for the motor, as well as the determination of operational horse power.

### Rotation Sensing

The first time the Evergreen IM is powered up and receives communication on both the **“High Voltage POWER”** connections and **“High Voltage SIGNAL”** connections, it will operate its Rotation Sensing feature. With this feature the motor will automatically determine the proper operating direction of the blower wheel without any wiring to configure.

During rotation sensing, the motor will turn on and off, running for a couple of seconds in each direction, sometimes but rarely more than twice before operating in the proper direction.

**Do not turn off the “High Voltage POWER” or the “High Voltage SIGNAL” to the motor until the motor continues to run in one direction for more than 60 seconds.** During rotation sensing the motor may start and stop in both directions a maximum of four times if needed to determine the proper operating direction. If the proper direction cannot be determined after the fourth sequence the motor will operate in the default direction of counter clock-wise (CCW).

After the motor has been running in one direction for more than 60 seconds, the rotation sensing feature is locked out. The motor will continue to start in this direction without performing the rotation sensing feature even if the “High Voltage POWER” is disconnected.

If the final operating direction of the motor is not the proper direction for the blower wheel, go to the “Troubleshooting Guidelines” on page 34 “The motor is operating in the wrong direction”.

## SEQUENCE OF OPERATION (CONTINUED)

### Basic Sequence of Operation

Following the HVAC systems sequence of operation, the Evergreen IM will determine its operational speed from the 24VAC thermostat demand connected to the Low Voltage SIGNAL connections.

The motor will then turn on at that speed only when the HVAC systems fan controls send 115VAC to the High Voltage SIGNAL connections.

When the thermostat demand ends and the 24VAC is de-energized from the Low Voltage SIGNAL connections the motor will continue to run at a reduced speed.

When the HVAC systems fan controls de-energize the 115VAC to the High Voltage SIGNAL connections the motor will turn off.

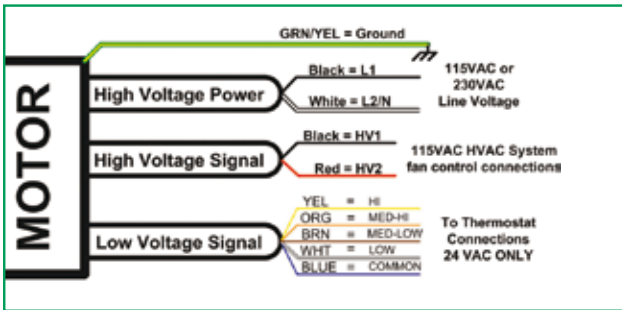

#### Important Note:

The Evergreen IM has numerous built in ramp timings to improve comfort and decrease the noise associated with changing speeds, turning on and turning off. The length of these ramps is determined by the HVAC System demand and if the motor is currently on, off or running constant fan. The following pages will cover each specific operation. It is important to understand that a ramp is different than a delay. A delay waits for a specified amount of time before action. A ramp uses the specified amount of time to change the motor operation from off to on, on to off or from one speed to another.

## SEQUENCE OF OPERATION (CONTINUED)

### SINGLE DEMAND TIME LINE

#### Motor On Command

1. HVAC System demand energizes 24VAC from thermostat connection to a Low Voltage SIGNAL (speed) tap. There is no motor operation at this point unless Step 2 occurs at the same time according the HVAC Systems fan control(s) sequence of operation. This allows the HVAC System to maintain any built in fan on delays.
2. HVAC System fan control(s) energize 115VAC to the High Voltage SIGNAL connection(s). Motor will ramp (15 second maximum ramp) up to the Low Voltage SIGNAL (speed) tap selection.

#### Motor Off Command

1. HVAC System demand de-energizes 24VAC from thermostat connection to the Low Voltage SIGNAL (speed) tap.
2. The motor will ramp down to a fixed reduced speed setting. Minimum ramp time 45 seconds. After 45 seconds the motor will continue to operate at the fixed reduced speed setting until the High Voltage SIGNAL connection(s) are de-energized. This allows the HVAC System to maintain any built in fan off delays.
3. HVAC System fan control(s) de-energize 115VAC from the High Voltage SIGNAL connection(s). Motor will ramp (15 second maximum ramp) to off. If this voltage is de-energized at the same time as Step 1 or during the ramp down specified in Step 2, the motor will begin its off ramp immediately.

The Low Voltage SIGNAL (speed) taps on the Evergreen IM are communication inputs, not motor windings like a PSC motor. The microprocessor is programmed to look at these taps for an operating (speed) value only. There can be more than one (speed) tap energized at the same time without damaging the motor.

The next sections will cover the sequence of operation for multiple demands and demand changes on the Low Voltage SIGNAL (speed) tap selections.

## SEQUENCE OF OPERATION (CONTINUED)

### MULTIPLE DEMAND TIME LINE

If multiple 24VAC thermostat demands are energized at the same time to the Low Voltage SIGNAL (speed) tap selections on the motor, it is designed to operate at the highest value tap selection and ignore the communication voltage on the lower value tap(s). Value equals the Low Voltage SIGNAL (speed) taps where high speed is the highest value and low speed is the lowest value.

Examples:

Air Conditioning or Heat Pump call on Y and G

Two Stage System call on both stages

### Motor On Command

1. HVAC System demand energizes 24VAC from thermostat connections to multiple Low Voltage SIGNAL (speed) taps. There is no motor operation at this point unless Step 2 occurs at the same time according to the HVAC Systems fan control(s) sequence of operation. This allows the HVAC System to maintain any built in fan on delays.
2. HVAC System fan control(s) energize 115VAC to the High Voltage SIGNAL connection(s). Motor will ramp (15 second maximum ramp) up to the highest value Low Voltage SIGNAL (speed) tap selection that is energized.

### Motor Off Command

1. HVAC System demand de-energizes 24VAC from thermostat connections to all of the Low Voltage SIGNAL (speed) taps.
2. The motor will ramp down to a fixed reduced speed setting. Minimum ramp time 45 seconds. After 45 seconds the motor will continue to operate at the fixed reduced speed setting until the High Voltage SIGNAL connection(s) are de-energized. This allows the HVAC System to maintain any built in fan off delays.
3. HVAC System fan control(s) de-energize 115VAC from the High Voltage SIGNAL connection(s). Motor will ramp (15 second maximum ramp) to off. If this voltage is de-energized at the same time as Step 1 or during the ramp down specified in Step 2, the motor will begin its off ramp immediately.

## SEQUENCE OF OPERATION (CONTINUED)

### DEMAND CHANGES DURING HVAC SYSTEM OPERATION

If there is an HVAC System demand change while the motor is operating, the motor will ramp, up or down, to the new speed of highest value. Value equals the Low Voltage SIGNAL (speed) taps where high speed is the highest value and low speed is the lowest value.

Examples:

Two stage systems changing from one stage to another.

Dual Fuel system changing from heat pump to fossil fuel heating.

If the HVAC System and motor are in full operation, with a 24VAC thermostat demand already energizing one or more Low Voltage SIGNAL (speed) taps and the High Voltage SIGNAL connection(s) are energized, the following sequences would occur.

1. If a new 24VAC thermostat demand energizes a (higher value) Low Voltage SIGNAL (speed) tap than is currently energized, the motor will ramp (minimum 45 seconds ramp) to the new higher speed.
2. If a new 24VAC thermostat demand energizes a (lower value) Low Voltage SIGNAL (speed) tap than is currently energized, the motor will ignore that communication.
3. If a (higher value) Low Voltage SIGNAL (speed) tap is de-energized while one or more (lower value) taps are still energized, the motor will ramp (minimum 45 seconds ramp) to the next (highest value) tap that is energized.

When the last Low Voltage SIGNAL (speed) tap is de-energized, the motor will follow the same sequence as described in the previous sections **“Motor Off Command”**.

### CONSTANT FAN OPERATION

If the 24VAC thermostat constant fan (G) line is connected to a Low Voltage SIGNAL (speed) tap, and the thermostat is set to Fan On, the HVAC Systems fan controls will energize the High Voltage SIGNAL connection(s) and the motor will run at that speed continuously. With the High Voltage SIGNAL connection(s) energized, the motor will ramp up (up to 45 seconds maximum ramp) to any new (higher value) Low Voltage SIGNAL (speed) tap energized from a system demand. At the end of all other demands, the motor will ramp down (up to 45 seconds maximum ramp) to the Low Voltage SIGNAL (speed) tap still energized by the (G) line.

## SEQUENCE OF OPERATION (CONTINUED)

### HIGH EFFICIENCY CONSTANT FAN OPERATION

If the 24VAC thermostat constant fan (G) is not connected to a Low Voltage SIGNAL (speed) tap, and the thermostat is set to Fan On, the motor will operate at a fixed high efficiency constant fan speed. This special speed was designed for decreased electrical usage and reduced system noise.

The Evergreen IM microprocessor has been programmed to interpret communication voltage on the High Voltage SIGNAL connection(s) with no communication on the Low Voltage SIGNAL (speed) tap connections as a call for the special high efficiency constant fan speed.

With the High Voltage SIGNAL connection(s) energized, the motor will ramp up (25 seconds minimum ramp) to the (highest value) Low Voltage SIGNAL (speed) tap energized from a 24VAC thermostat demand. At the end of all Low Voltage SIGNAL (speed) tap demands, the motor will ramp down (45 seconds minimum ramp) to the special high efficiency constant fan speed.

## Maintenance

The Evergreen IM motor is permanently lubricated and requires no maintenance.

Any signs of water damage on the replaced PSC motor, in the HVAC system or on the Evergreen IM should be taken very seriously. Fix the water issues immediately. If there are any signs of water damage to the Evergreen IM motor it should be replaced to prevent serious injury to the occupants and the property.

All HVAC systems require annual maintenance for proper operation and to maintain maximum efficiency and capacity. See the HVAC system manufacturer's manuals for proper inspection and maintenance requirements. To keep the Evergreen IM motor and the airside components clean, install and regularly maintain high quality properly sized filters.

# TROUBLESHOOTING GUIDELINES

Symptom	Potential Problem	Solution
<p>The motor does not run.</p> <p><b>WARNING:</b> ALWAYS DISCONNECT MAIN HVAC SYSTEM POWER BEFORE DISCONNECTING OR RE-CONNECTING ANY WIRES OR CONNECTORS TO THE EVERGREEN MOTOR.</p> <p><b>IMPORTANT NOTE:</b> There must be proper voltage at the <b>High Voltage POWER</b> and <b>High Voltage SIGNAL</b>, connections for the motor to operate. Skipping any of the troubleshooting in this section could result in misdiagnosis of the motor and/or HVAC system</p>	<p>The wrong Line Voltage jumper is installed.</p> 	<p>For 230VAC systems the yellow jumper should be installed. For 115VAC systems the white jumper should be installed. <b>NOTE: If the motor was powered with 230VAC while the white jumper was installed, the motor may be permanently damaged and need to be replaced.</b> Continue troubleshooting here after proper jumper is installed.</p>
	<p>There is not correct voltage at the <b>High Voltage POWER</b> connections.</p>	<p>Confirm proper system line voltage is connected. Measure the voltage at the High Voltage POWER connections L1 (black) and L2/N (white). On 115VAC systems, Neutral should be connected to L2/N. The power connected to these taps should be continuous un-switched line voltage. <b>This voltage alone will not operate the motor.</b> If proper voltage is not present, troubleshoot the HVAC system. Continue troubleshooting here after proper voltage has been confirmed.</p>
	<p>There is not correct voltage on the <b>High Voltage SIGNAL</b> connections.</p>	<p>Confirm there is a 115VAC demand on any one or all of the High Voltage SIGNAL connections. The High Voltage SIGNAL connections of the motor should only be connected to the HVAC Systems 115VAC fan controls (fan relay or circuit board) connections. On 230VAC systems, the 115VAC line voltage connected to the High Voltage POWER L1 (Black) wire must be the same polarity as the 115VAC fan output voltage from the HVAC system controls. <b>If proper voltage is not present, troubleshoot the HVAC system. On 230VAC systems, measure the voltage from the High Voltage Signal Connection(s) to the High Voltage Power L2 connection. If this reading is not 230VAC, reverse the High Voltage Power L1 and L2 connections from the motor.</b></p>
	<p><b>Final Diagnosis.</b></p>	<p>If there is a 115VAC demand on one or more of the High Voltage SIGNAL connections, the correct Line Voltage jumper is installed, there is proper voltage on the High Voltage POWER connections and the motor is not operating, replace the motor.</p>



## TROUBLESHOOTING GUIDELINES (CONTINUED)

See pages 7-8 for complete wiring instructions on the High Voltage POWER connections.

See pages 9-12 for complete wiring instructions on the High Voltage SIGNAL connections

See pages 13-14 for complete wiring instructions on the Low Voltage SIGNAL connections.

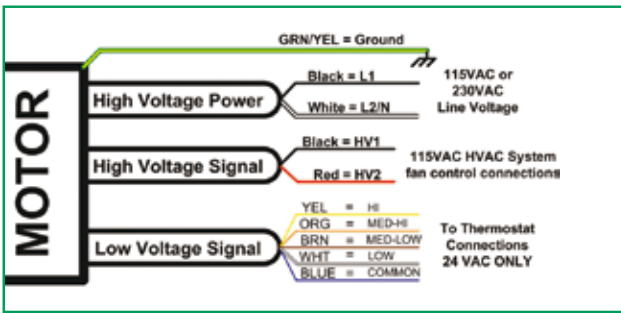

## HORSE POWER (HP) SELECTION CHART

1/2 Hp Motor	┌ └	HV1 & HV2 = 1/2 - 1/3 Hp operation
		HV1 = 1/3 - 1/4 Hp operation
		HV2 = 1/4 - 1/5 Hp operation

1 Hp Motor	┌ └	HV1 & HV2 = 3/4 - 1 Hp operation
		HV1 = 3/4 - 1/2 Hp operation
		HV2 = 1/2 Hp operation

## SELECTING THE CORRECT REPLACEMENT MOTOR

Check off the HVAC systems existing PSC motor horse power (Hp) and HVAC equipment size to determine the Evergreen IM sizing. Use the motor that best matches the HVAC system sizing.

1/5 - 1/2 Hp	___	┌ └	1/2 Hp Evergreen IM
1.5 - 3 Ton	___		
40 - 95k BTUH	___		

1/2 - 1 Hp	___	┌ └	1 Hp Evergreen IM
3.5 - 5 Ton	___		
100 - 150k BTUH	___		

## TROUBLESHOOTING GUIDELINES (CONTINUED)

Symptom	Potential Problem	Solution
<p>The motor is running but there is not enough airflow causing any of the following:</p> <p>Proper heating temperature rise or cooling/heat pump CFM cannot be achieved</p> <p><b>OR</b></p> <p>The indoor coil is freezing in the cooling mode</p> <p><b>OR</b></p> <p>The head pressure switch is tripping in the heating mode (heat pumps)</p> <p><b>OR</b></p> <p>The electric strips are tripping on thermal overload</p> <p><b>OR</b></p> <p>The main limit is tripping.</p>	<p>The proper Line Voltage jumper is not installed.</p>	<p>For 230VAC systems the yellow jumper should be installed. For 115VAC systems the white jumper should be installed.</p> <p><b>NOTE: If the motor was powered with 115VAC while the yellow jumper was installed, the motor will run but at a reduced airflow than expected.</b></p> <p>Continue troubleshooting here after proper jumper is installed.</p>
<p><b>WARNING:</b> ALWAYS DISCONNECT MAIN HVAC SYSTEM POWER BEFORE DISCONNECTING OR RE-CONNECTING ANY WIRES OR CONNECTORS TO THE EVERGREEN MOTOR.</p>	<p>The wrong speed tap is selected or there is no communication to the Low Voltage SIGNAL connections.</p> <p>The Horse Power selection is too low/ Improper High Voltage SIGNAL connections.</p>	<p>Confirm the proper HVAC system 24VAC thermostat demand is connected to a Low Voltage SIGNAL (speed) tap. <b>Any voltage above 30VAC could permanently damage the motor.</b> This voltage alone will not operate the motor. Confirm there is proper 24VAC between the selected Low Voltage SIGNAL (speed) tap and the BLUE Common tap on the motor. If more airflow is required change this connection to a higher speed tap. If the highest speed tap does not achieve the required airflow, the horse power (Hp) selection may need to be adjusted. If proper voltage is not present, troubleshoot the HVAC system. Continue troubleshooting here if this does not solve the problem.</p> <p><b>CAUTION: Adjusting the Horse Power (Hp) selection will change the airflow value of all Low Voltage SIGNAL (speed) taps. If the Hp selection is changed, airflow in all demands will need to be checked and adjusted as needed.</b> To achieve the proper horse power (Hp) the High Voltage SIGNAL connections must be connected to the HVAC Systems fan controls according to the chart on the previous page. When the motor was installed it should have been configured to match the Hp of the replaced motor. If the airflow is too low, configure to a higher Hp setting.</p> <p>If the highest Hp setting and the highest Low Voltage SIGNAL (speed) tap do not achieve the required airflow, continue troubleshooting on the next page.</p>

## TROUBLESHOOTING GUIDELINES (CONTINUED FROM PAGE 29)

Symptom	Potential Problem	Solution
<p>The motor is running but there is not enough airflow causing any of the following:</p> <p>Proper heating temperature rise or cooling/heat pump CFM cannot be achieved</p> <p><b>OR</b></p> <p>The indoor coil is freezing in the cooling mode</p> <p><b>OR</b></p> <p>The head pressure switch is tripping in the heating mode (heat pumps)</p> <p><b>OR</b></p> <p>The electric strips are tripping on thermal overload</p> <p><b>OR</b></p> <p>The main limit is tripping.</p> <p><b>WARNING:</b> ALWAYS DISCONNECT MAIN HVAC SYSTEM POWER BEFORE DISCONNECTING OR RE-CONNECTING ANY WIRES OR CONNECTORS TO THE EVERGREEN MOTOR.</p>	<p>The motor is running the wrong direction.</p> <p>The wrong motor was selected.</p> <p>There is an airflow restriction in the HVAC system.</p>	<p>Go to page 34 “The motor is operating in the wrong direction”.</p> <p>This motor is designed to replace multiple motors based on horse power and system sizing. If the sizing of the motor is in question, please see page 30 “Selecting the Correct Replacement Motor”.</p> <p><b>CAUTION: Do not install the larger motor to solve an airflow problem.</b> This could cause many other worse problems including rotation issues, noise and hub failure. If the motor is properly sized, see the next section on “Airflow Restrictions”.</p> <p>Airflow restrictions can be caused by any one or more of the following:</p> <ul style="list-style-type: none"> <li>• Dirty filters.</li> <li>• Dirty blower wheel, secondary heat exchanger and/or evaporator coil.</li> <li>• Too many registers, grilles and/or balancing dampers closed.</li> <li>• Dirty, damaged, or poorly constructed ductwork.</li> </ul> <p>All of these issues can be solved by visual inspection and cleaning. If this does not solve the problem continue here.</p> <p>Check the Total External Static Pressure (TESP) only after the issues listed above have been checked and corrected.</p> <p>If the TESP is above .8, there is an issue with the ductwork or filter sizing that must be corrected.</p> <p>After correcting one or more airflow restrictions, it may be possible to lower the speed selection.</p>

## TROUBLESHOOTING GUIDELINES (CONTINUED)

Symptom	Potential Problem	Solution
<p>The motor is running with no demand from the HVAC System.</p>	<p>There is a constant fan call from the thermostat.</p> <p><b>WARNING:</b> ALWAYS DISCONNECT MAIN HVAC SYSTEM POWER BEFORE DIS-CONNECTING OR RE-CONNECTING ANY WIRES OR CONNECTORS TO THE EVERGREEN MOTOR.</p>	<p>The Evergreen IM is designed to operate a special constant fan speed if there is power on the High Voltage POWER connections and the High Voltage SIGNAL connections with no power on the Low Voltage SIGNAL (speed) connections.</p> <p>If there is a constant fan call from the thermostat this is normal.</p> <p>If there is not a constant fan call from the thermostat check the High Voltage SIGNAL connections. If they are connected to a constant 120vac source refer to the wiring diagrams on pages 9-12.</p>
<p>There is too much airflow and/or any of the following:</p> <p>The temperature rise is too low <b>OR</b> The electric strip heat airflow is too cold <b>OR</b> There is no dehumidification in the A/C mode.</p>	<p>The selected speed, horse power or motor is too high.</p> <p><b>WARNING:</b> ALWAYS DISCONNECT MAIN HVAC SYSTEM POWER BEFORE DIS-CONNECTING OR RE-CONNECTING ANY WIRES OR CONNECTORS TO THE EVERGREEN MOTOR.</p>	<p>To reduce the speed of the motor, change the Low Voltage SIGNAL (speed) connection to the thermostat demand to a lower value. <i>See the wiring diagram on page 30.</i></p> <p>To reduce the horse power of the motor change the High Voltage SIGNAL connection(s) to the HVAC System fan controls. <i>See the selection chart on page 30.</i></p> <p>If the motor is on the lowest horse power and the lowest speed and there is still too much airflow, the motor selections is too big for the HVAC system.</p>
<p>The motor turns on and off multiple times when the main power to the HVAC system is reset.</p>	<p>The motor is performing a rotation sensing.</p> <p>The rotation sensing feature should only perform once, the first time the motor is turned on or if it has been reset as described on the next page.</p>	<p>See "Rotation Sensing" page 23. If the motor has been operating properly for more than 60 seconds but continues to perform the rotation sensing feature any time the High Voltage Power to the motor is disconnected, please call the Evergreen Hotline at 866-503-8566.</p>

## TROUBLESHOOTING GUIDELINES (CONTINUED)

Symptom	Potential Problem	Solution
The motor is operating in the wrong direction.	The rotation sensing feature needs to be reset.  <b>WARNING:</b> ALWAYS DISCONNECT MAIN HVAC SYSTEM POWER BEFORE DISCONNECTING OR RE-CONNECTING ANY WIRES OR CONNECTORS TO THE EVERGREEN MOTOR.	<ol style="list-style-type: none"> <li>1. Disconnect the main power to the HVAC system.</li> <li>2. Disconnect the High Voltage SIGNAL connection(s) from the motor to the HVAC system.</li> <li>3. Reconnect the main power to the HVAC system. Confirm there is proper voltage to the High Voltage POWER connections on the motor.</li> <li>4. Energize any of the Low Voltage SIGNAL (speed) tap selections continuously for a minimum of 5 minutes.</li> <li>5. Disconnect the main power to the HVAC system for a minimum of 1 minute. Confirm there is no voltage to the High Voltage POWER connections on the motor. During this time reconnect the High Voltage SIGNAL connection(s).</li> </ol>

Now the Rotation Sensing feature will operate as described on page 23 “Rotation Sensing”. If the motor does not perform the Rotation Sensing feature, repeat this procedure carefully and confirm all timings with a watch.

If the motor again selects the wrong direction, confirm that the selected Evergreen IM is not too large for the system. See the selection chart on page 30. If the motor has not been sized properly, replace the motor. If the motor meets the selection criteria please call the Evergreen Hotline at 866-503-8566.

If the troubleshooting guidelines provided here do not solve the problem or you have a problem not listed here please contact:

**Evergreen Contractor Hotline 1-866-503-8566**

**If the Evergreen IM needs to be replaced, it must be a direct Evergreen IM replacement.**

# Installation Worksheet

## EVERGREEN IM SELECTION DATA

Check off the HVAC systems existing PSC motor horse power (Hp) and HVAC equipment size to determine the Evergreen IM sizing. Use the motor that best matches the HVAC System sizing.

1/5 - 1/2 Hp	_____	} 1/2 Hp Evergreen IM	1/2 - 1 Hp	_____	} 1 Hp Evergreen IM
1.5 - 3 Ton	_____		3.5 - 5 Ton	_____	
40 - 95k BTUH	_____		100 - 150k BTUH	_____	

## REPLACED PSC MOTOR DATA

### HEAT PUMP SYSTEMS

Cooling/Heating Speed	Hi	MHi	MLo	Lo	TESP	_____
Cooling/Heating Speed (1st Stage)	Hi	MHi	MLo	Lo	TESP	_____
Emer. Heat Speed	Hi	MHi	MLo	Lo	TESP	_____ TR_____
Furnace Heat Speed	Hi	MHi	MLo	Lo		_____
Furnace Heat Speed (1st Stage)	Hi	MHi	MLo	Lo		_____

### AIR CONDITIONING AND/OR GAS, PROPANE OR OIL HEATING SYSTEMS

Cooling Speed	Hi	MHi	MLo	Lo	TESP	_____
Cooling Speed (1st Stage)	Hi	MHi	MLo	Lo	TESP	_____
Heating Speed	Hi	MHi	MLo	Lo		_____
Heating Speed (1st Stage)	Hi	MHi	MLo	Lo		_____

## HIGH VOLTAGE SIGNAL CONNECTIONS

Identify the horse power (Hp) rating of the replaced PSC motor. Use the following chart to determine which High Voltage SIGNAL (HV) connection(s) to use.

1/2 Hp Motor	}	HV1 & HV2 = 1/2 - 1/3 Hp operation	1 Hp Motor	}	HV1 & HV2 = 3/4 - 1 Hp operation
		HV1 = 1/3 - 1/4 Hp operation			HV1 = 3/4 - 1/2 Hp operation
		HV2 = 1/4 - 1/5 Hp operation			HV2 = 1/2 Hp operation

## INSTALLED EVERGREEN IM SET-UP DATA

### HEAT PUMP SYSTEMS

Cooling/Heating Speed	Hi	MHi	MLo	Lo	TESP	_____
Cooling/Heating Speed (1st Stage)	Hi	MHi	MLo	Lo	TESP	_____
Emer. Heat Speed	Hi	MHi	MLo	Lo	TESP	_____ TR_____
Furnace Heat Speed	Hi	MHi	MLo	Lo		_____
Furnace Heat Speed (1st Stage)	Hi	MHi	MLo	Lo		_____

### AIR CONDITIONING AND/OR GAS, PROPANE OR OIL HEATING SYSTEMS

Cooling Speed	Hi	MHi	MLo	Lo	TESP	_____
Cooling Speed (1st Stage)	Hi	MHi	MLo	Lo	TESP	_____
Heating Speed	Hi	MHi	MLo	Lo		_____
Heating Speed (1st Stage)	Hi	MHi	MLo	Lo		_____



# Need Additional Evergreen Help?



**Evergreen**®

Powered by ECM Technology

**Contractor Hotline:**  
**1.866.503.8566**

[www.EvergreenDealer.com](http://www.EvergreenDealer.com)  
[www.theDealerToolbox.com](http://www.theDealerToolbox.com)

**Reminder:** Please remember to leave this manual near the HVAC system and install the System ID Label (with completed information) near the HVAC systems wiring diagram.

